

352-066 EARLY YEARS WORK TABLE - LEGS & HARDWARE

Page 1 of 1
Rev 04-01-03

*** IMPORTANT ***

Please retain this instruction sheet in your files. It contains important maintenance instructions, as well as replacement parts information.

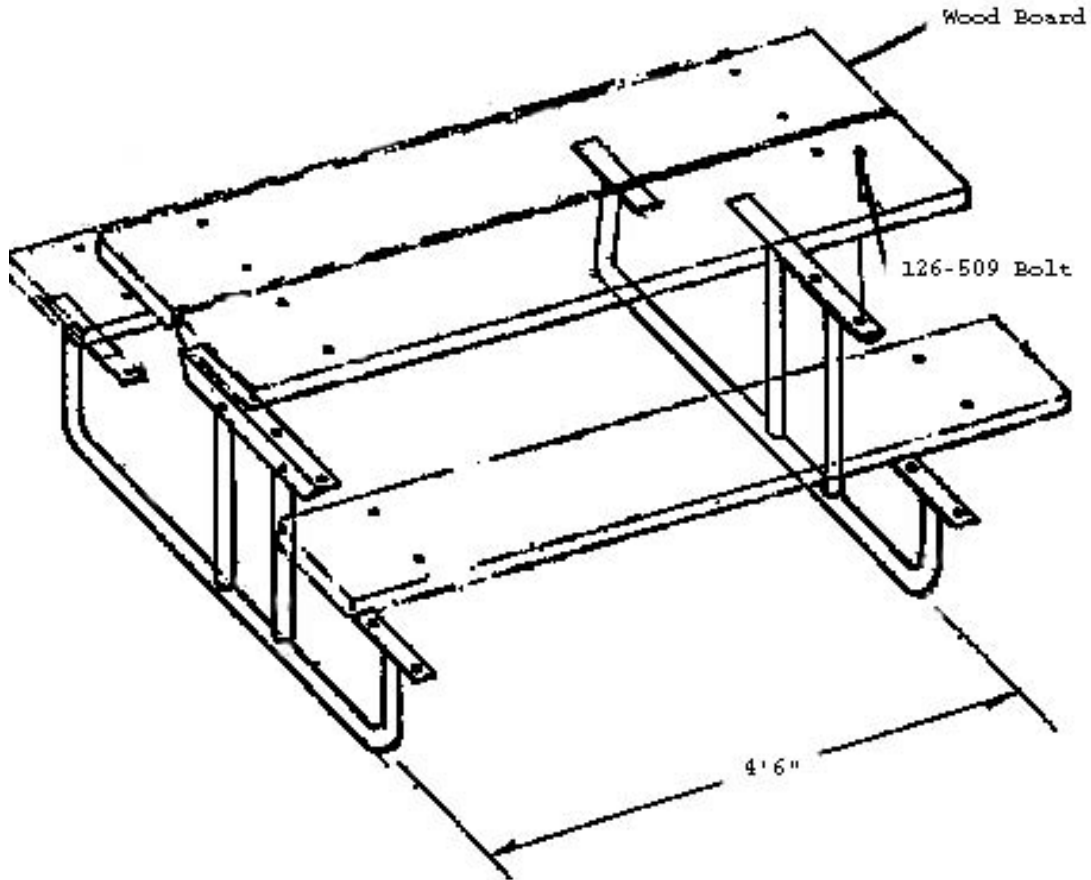

Packing List

<u>PARTS LIST</u>			<u>HARDWARE BAG</u>		
1	CTN	1 - Hardware Bag	16	-	126-509 5/16" x 2 1/4" Carriage Bolts
		2 - 353-916 Angles	4	-	116-506 5/16" x 1 1/2" Hex Bolts
2	WF	2 - 353-915 Legs	20	-	316-501 5/16" Flat Washers
			20	-	216-501 5/16" Hex Nuts

1 CTN	2 WF	3 TOTAL PCS	WT 45#	CLASS 70
-------	------	-------------	--------	----------

GENERAL ASSEMBLY INSTRUCTIONS

1. Check each Piece CAREFULLY and REMOVE ANY SHARP PROJECTIONS that may have been caused by shipping.
2. DO NOT TIGHTEN nuts more than hand tight until ENTIRE ASSEMBLY IS COMPLETED.
3. ALL THREADED ENDS of bolts protruding BEYOND NUTS should be CUT OFF and PEENED OVER to remove any SHARP EDGE.

SPECIFIC ASSEMBLY INSTRUCTIONS

1. Assemble bench using 2" x 10" x 6' or 8' length wood boards. Mark and drill wood boards 12" from ends using the centered frame as a template.
2. Mark and dig footings
3. Prop in holes and pour concrete – allow at least 48 hours for concrete to harden.
4. If installation is on blacktop, footings should be left 3" below surface but crowned for drainage. After concrete hardens fill in with dirt. This also applies if installation is in sand, wood chips, or other soft surfaces.