

581-502 4 1/2" OD Single Post 2 Seat Swing

* IMPORTANT *

Please retain this instruction sheet in your files. It contains important replacement parts information. All equipment should be installed in accordance with these instructions. It is important to use and maintain all public playground equipment properly. Playground equipment, which is improperly maintained, can cause serious injury. Periodical inspections, maintenance, repair and/or replacement of damaged parts is necessary for safe operation of equipment and safety of users. Resilient surfacing should be used under all playground equipment. Appropriate publications, available at no charge, from the Consumer Product Safety Commission, include "A Handbook for Public Playground Safety". You can receive your free copy by calling 1-301-504-0708.

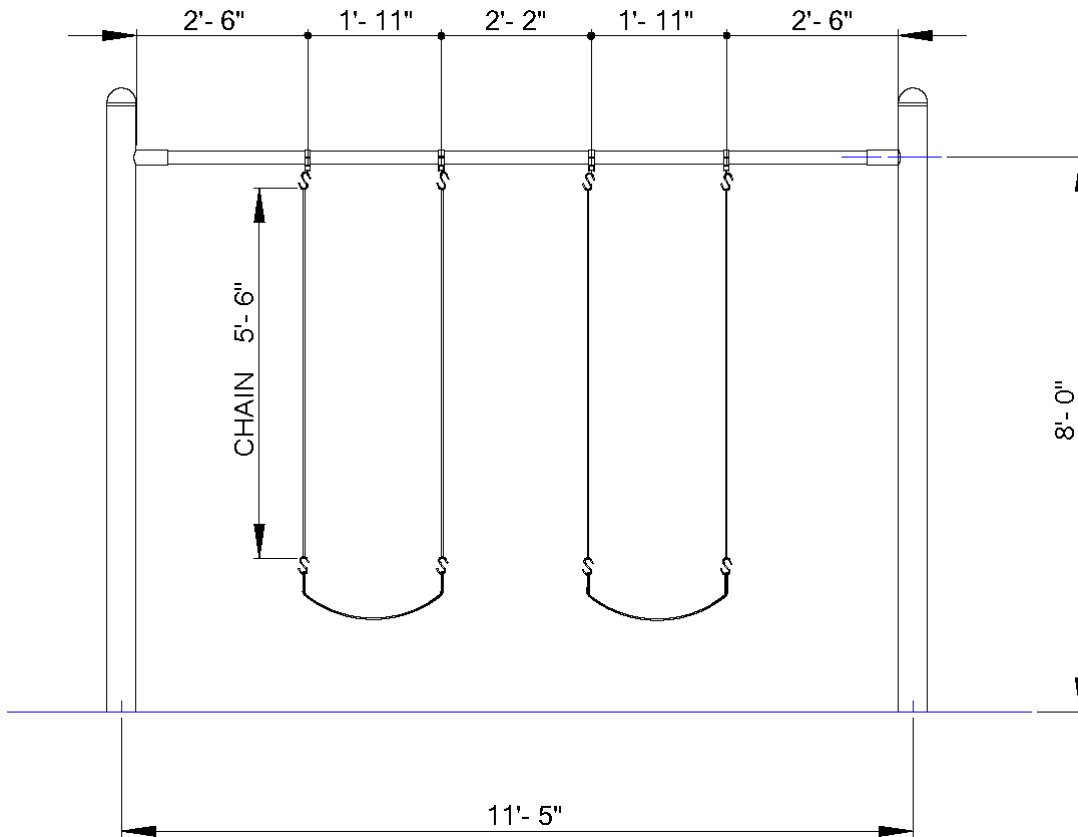

PACKING LIST

1 CTN		Hardware Bag
2 PIPE	1 583-510	4 1/2" OD x 11'4" end post
1 PIPE	3 343-210A	2 3/8" OD x 11' Long

HARDWARE BAG

2	196-802	1/2" x 1/2" Socket Set Screw
4	317-140	4/0 Chain x 5'6" long
1	416-400	1/4" Socket Key
4	585-520	2 3/8" Swing Hanger
8	585-901	S-Hook
2	585-955	Cut Proof Belt Seat
1	805-532	Warning Label
1	805-534	SportsPlay Label
1		Maintenance Checklist

1 CTN	3 PIPE	4 TOTAL PCS	TOTAL WT 355#	CLASS 70
-------	--------	-------------	---------------	----------

581-502 4 1/2" OD Single Post 2 Seat Swing

GENERAL FOOTING RECOMMENDATIONS

Diameter & Depth of footings illustrated are satisfactory in most applications for pipe sizes up to 5" diameter. Varying soil & climatic conditions may require deeper & heavier footings in some areas. Check local building codes.

Diagram:
Permanent Installation

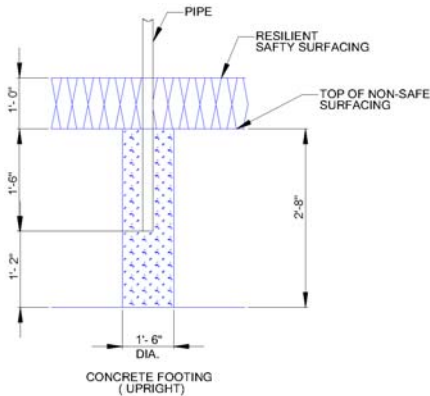
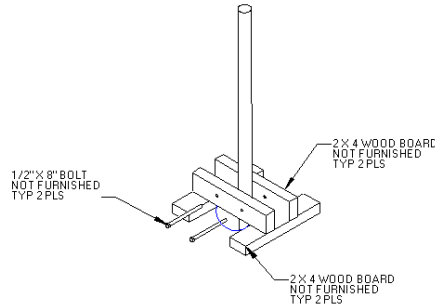
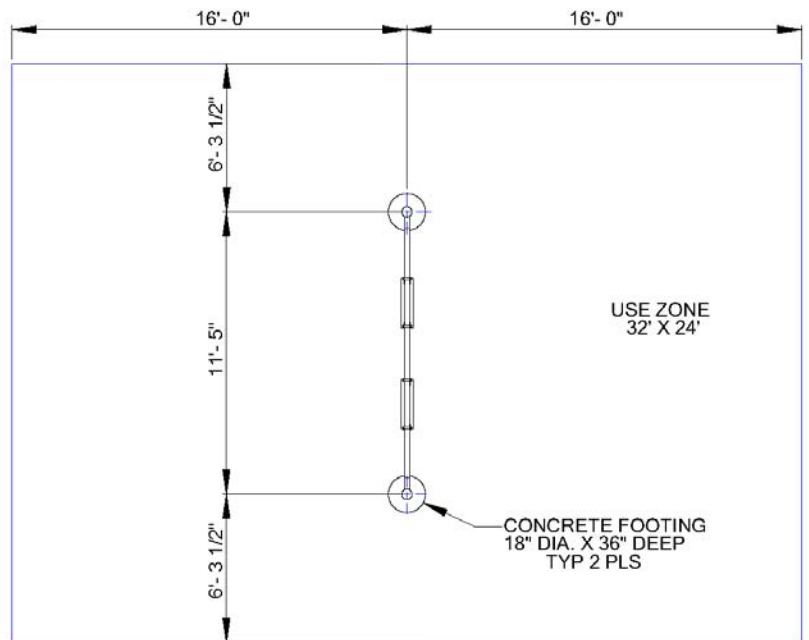
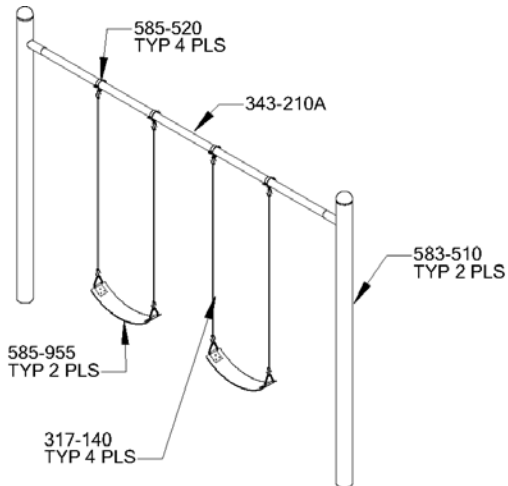

Diagram:
Suggested Bracing Method



* If resilient surfacing is to be less than 12", then additional pipe should be put in concrete to maintain proper finish grade for equipment.

USE AREA AND FOOTING LAYOUT:



581-502 4 1/2" OD Single Post 2 Seat Swing

GENERAL USE/FALL ZONE & FOOTING RECOMMENDATIONS

SINGLE AXIS SWINGS:

The Use/Fall Zone should extend to the front & rear, a minimum distance of twice the height of the Top Rail above the resilient surfacing material. The Use/Fall Zone to the sides should follow the general recommendation of six feet minimum. This six-foot zone may overlap that of an adjacent swing structure.

ROTATING SWINGS:

The Use/Fall Zone should extend in all directions the length of the swing chain plus six feet. The six-foot minimum fall zone from the supporting structure also applies, and may overlap the six-foot zone of an adjacent swing structure.

GENERAL MAINTENANCE INSTRUCTIONS:

Check MONTHLY for loose bolts, damaged or broken parts. Tighten and/or replace immediately. On swings and any equipment that uses S-Hooks and/or Swing Hangers check the bearing surfaces for wear. Replace any parts that show a reduction of 25% from the original size.

SPECIFIC ASSEMBLY INSTRUCTIONS:

NOTE: DO NOT tighten nuts more than hand-tight until entire assembly is completed.

STEP #1: Assemble swing frame on side on ground. If more than one section, assemble section by section. Lay out parts so that when frame is erected, legs will be in approximately the correct position.

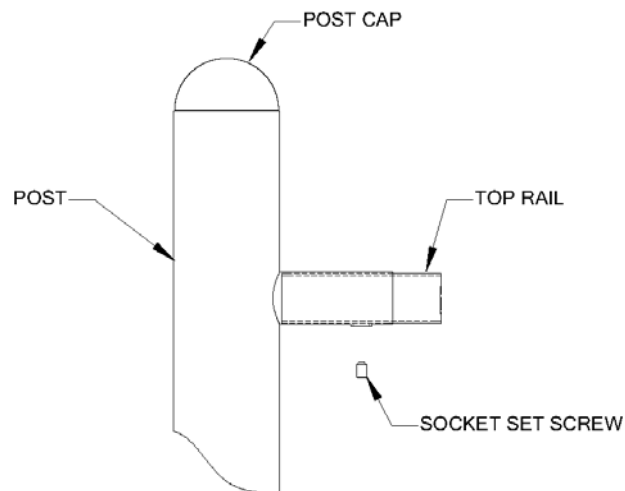

581-502 4 1/2" OD Single Post 2 Seat Swing

Page 4

Rev 10/28/04

STEP #2: Remove swing hanger pendulums from the swing hanger assemblies. Using S-hooks, attach seats to chain and chain to swing hanger eyehook. Close the S-hooks to within .034" (1/32") using S-hook pliers or pounding with a hammer.

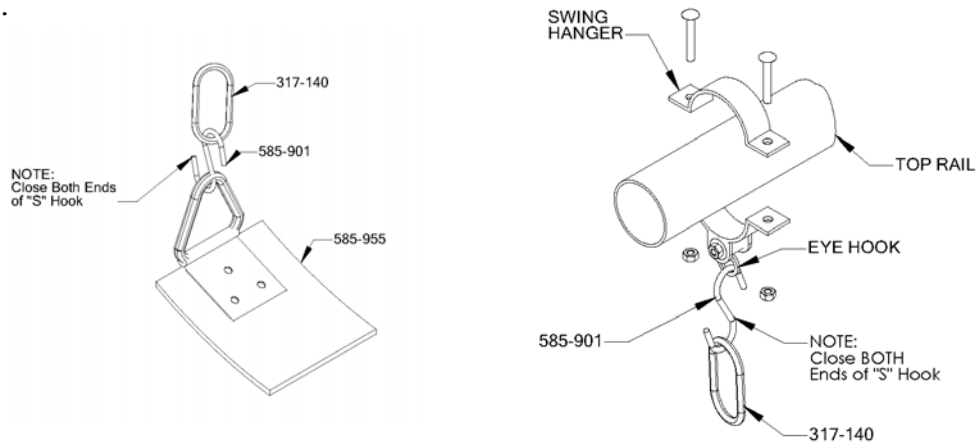

STEP #3: Assemble top portion of Swing Hangers on Top Rail following spacing on Page #1.

STEP #4: Footing holes may be marked out and dug from footing layout, however, it is easier to position swing in proper location, mark holes, move swing aside, and dig holes. Dig holes 18" in diameter and 36" deep for the large pipe posts.

STEP #5: Stand swing upright onto legs and brace in footing holes so that 18" of pipe will be under intended level of resilient surfacing and top rail is at desired height.

STEP #6: Plumb and level entire unit. Use short length of pipe on end of socket key to add leverage when tightening socket set screws. Pour concrete. Dome top of cement for proper drainage. Wait 48 hours before removing braces, applying resilient surfacing and using equipment.

STEP #7: Attach assembled seats to swing hangers by reattaching the bearing hooks to the swing hangers. SEE STEP #2. OD NOT overtighten bolt on pendulum. Hangers must move freely.

STEP #8: Attach warning label and Manufacturer's Identification label to a clean surface. The labels should be attached in a location where they are clearly visible and legible and away from normal hand and foot placement areas. The labels must be replaced if they become illegible, destroyed or removed. Contact your SportsPlay distributor for replacements.

Maintenance: Periodically, tighten all loose parts and check for wear and/or damage. If wear/damage is found, discontinue use of unit until repairs are completed.