

# 801-175 5' SINGLE ENTRY BIKE RACK (Perm)

## I M P O R T A N T

Please retain this instruction sheet in your files. It contains important maintenance instructions, as well as replacement parts information.

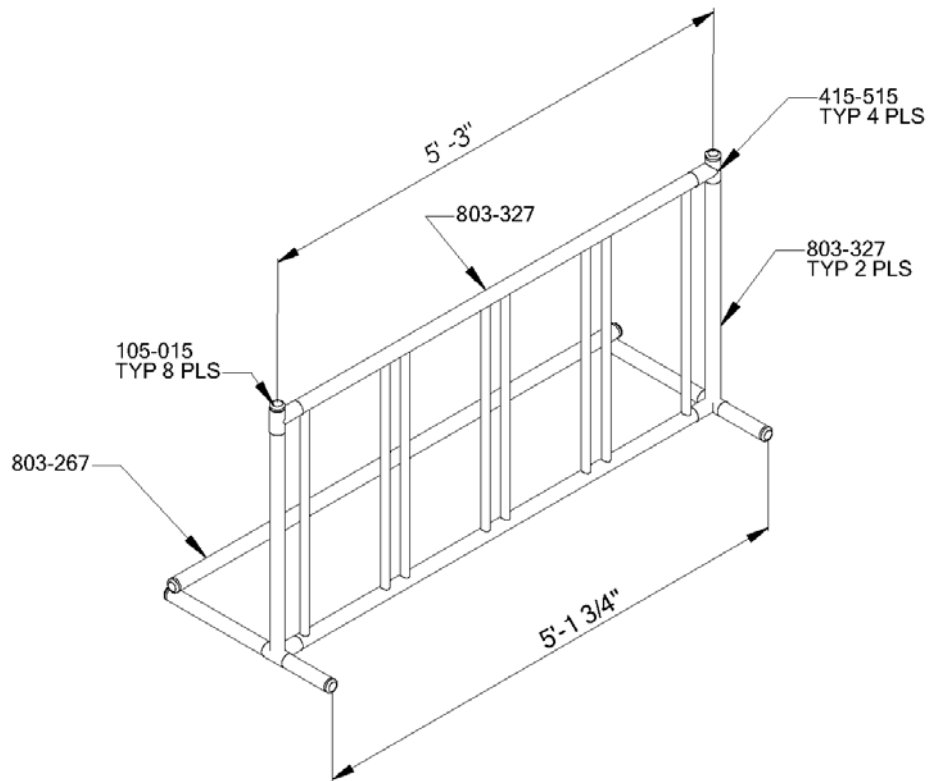

### PACKING LIST

|   |     |           |              |
|---|-----|-----------|--------------|
| 1 | CTN |           | Hardware Bag |
| 1 | BDL | 2 803-261 | Spacer Bar   |
| 1 | BDL | 2 803-262 | End Support  |
| 2 | WF  | 2 803-326 | Ladder       |

### HARDWARE BAG

|      |         |                         |
|------|---------|-------------------------|
| 2    | 116-514 | 5/16" x 3 1/2" Hex Bolt |
| 8    | 116-510 | 5/16" x 2 1/2" Hex Bolt |
| 8    | 326-501 | 5/16" Lock Washer       |
| 4    | 216-501 | 3/8" Hex Nut            |
| 4    | 226-501 | 3/8" Lock Nut           |
| 12   | 226-501 | 5/16" Lock Nut          |
| 4 pr | 415-515 | 1 5/8" T-Clamp          |
| 2    | 105-015 | 1 5/8" Pipe Plug        |

|       |       |      |             |        |          |
|-------|-------|------|-------------|--------|----------|
| 1 CTN | 2 BDL | 1 WF | 4 TOTAL PCS | WT 50# | CLASS 70 |
|-------|-------|------|-------------|--------|----------|

## 801-175 5' SINGLE ENTRY BIKE RACK (Perm)

Page 2

Rev 03/19/03

### GENERAL ASSEMBLY INSTRUCTIONS:

Check all the parts and hardware with the packing list too be sure you have received everything needed to assemble this product. CONTACT YOUR LOCAL DISTRIBUTOR OR SPORTSPLAY EQUIPMENT WITH NOTIFICATION OF ANY MISSING OR DAMAGED PARTS. Contact must be made within ten days of receipt of your order.

Only hand tighten nuts & bolts on initial assembly. Final tightening should be done **EVENLY** after final assembly when unit has been plumbed & leveled.

After assembly is complete, ANY ENDS OF BOLTS PROTRUDING BEYOND NUTS SHOULD BE CUT OFF AND/OR PEENED OVER TO REMOVED ANY SHARP PROJECTIONS. Go over entire unit to file smooth any sharp edges or projections that may have been caused by rough handling in shipping or installation. T-Clamps are designed for both one and two bolt connections. In many situations only one bolt is required. See specific assembly instructions.

On products with platforms install 1-2 degrees off level to facilitate water drainage.

### GENERAL MAINTENANCE INSTRUCTIONS:

Check **MONTHLY** for loose bolts, damaged or broken parts. Tighten and/or replace immediately.

### SPECIFIC ASSEMBLY INSTRUCTIONS:

- STEP #1: Completely assemble Bike Rack.
- STEP #2: Position Bike Rack in proper position, mark footing holes, move Bike Rack to one side, and dig holes.
- STEP #3: Assemble Anchor Bolts too end supports and place Bike Rack in position over footing holes.
- STEP #4: Pour concrete. Wait 48 hours before using equipment.

### T-Clamp Detail:

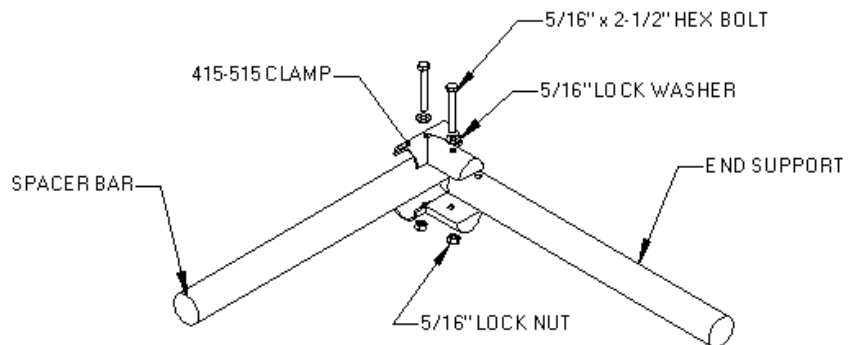

# 801-175 5' SINGLE ENTRY BIKE RACK (Perm)

Page 3

Rev 03/19/03

End Support and Spacer Detail:

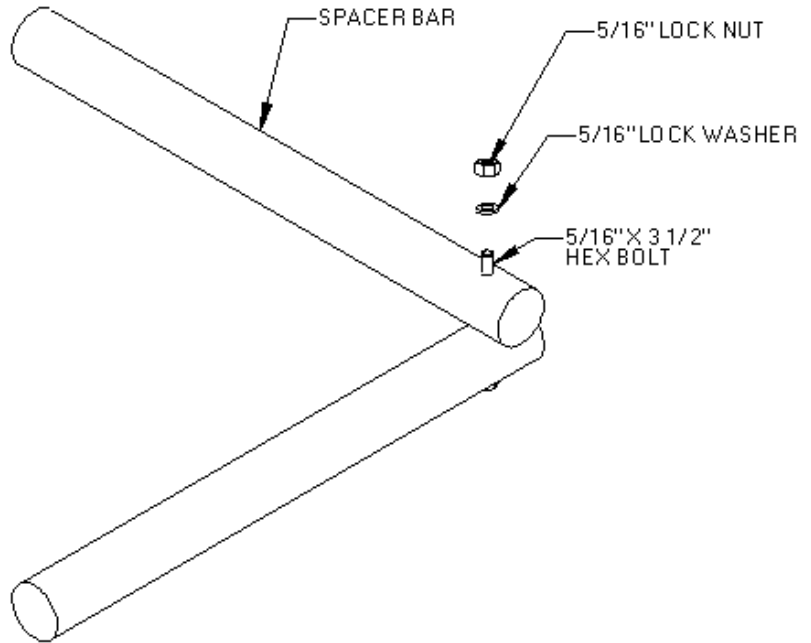

Anchor Bolt Detail:

