

# 802-176 10' SINGLE SIDE BIKE RACK (Port)

Page 1  
Rev 03/21/03

## I M P O R T A N T

Please retain this instruction sheet in your files. It contains important maintenance instructions, as well as replacement parts information.

Spacing between tire support posts is 3" center to center for small gap, 8 ½" center to center for large gap.

### PACKING LIST

### HARDWARE BAG

1	CTN		Hardware Bag	2	116-514	5/16" x 3 ½" Hex Bolt
1	BDL	1 803-268	Spacer Bar	8	116-510	5/16" x 2 ½" Hex Bolt
1	BDL	2 803-267	End Support	10	326-501	5/16" Lock Washer
1	WF	1 803-328	Ladder	10	226-501	5/16" Lock Nut
				4 pr	415-515	1 5/8" T-Clamp
				8	105-015	1 5/8" Pipe Plug

1 CTN	1 PIPE	1 BDL	1 WF	4 TOT PCS. WT 100#	CLASS 70
-------	--------	-------	------	--------------------	----------

## 802-176 10' SINGLE SIDE BIKE RACK (Port)

Page 2  
Rev 03/21/03

### GENERAL ASSEMBLY INSTRUCTIONS:

Check all the parts and hardware with the packing list too be sure you have received everything needed to assemble this product.

CONTACT YOUR LOCAL DISTRIBUTOR WITH NOTIFICATION OF ANY MISSING OR DAMAGED PARTS. Contact must be made within ten days of receipt of your order.

Only hand-tighten nuts & bolts on initial assembly. Final tightening should be done **EVENLY** after final assembly when unit has been plumbed & leveled.

After assembly is complete, ANY ENDS OF BOLTS PROTRUDING BEYOND NUTS SHOULD BE CUT OFF AND/OR PEENED OVER TO REMOVED ANY SHARP PROJECTIONS. Go over entire unit to file smooth any sharp edges or projections that may have been caused by rough handling in shipping or installation. T-Clamps are designed for both one and two bolt connections. In many situations only one bolt is required. See specific assembly instructions.

On products with platforms install 1-2 degrees off level to facilitate water drainage.

### GENERAL MAINTENANCE INSTRUCTIONS:

Check **MONTHLY** for loose bolts, damaged or broken parts. Tighten and/or replace immediately.

### T-Clamp Detail:

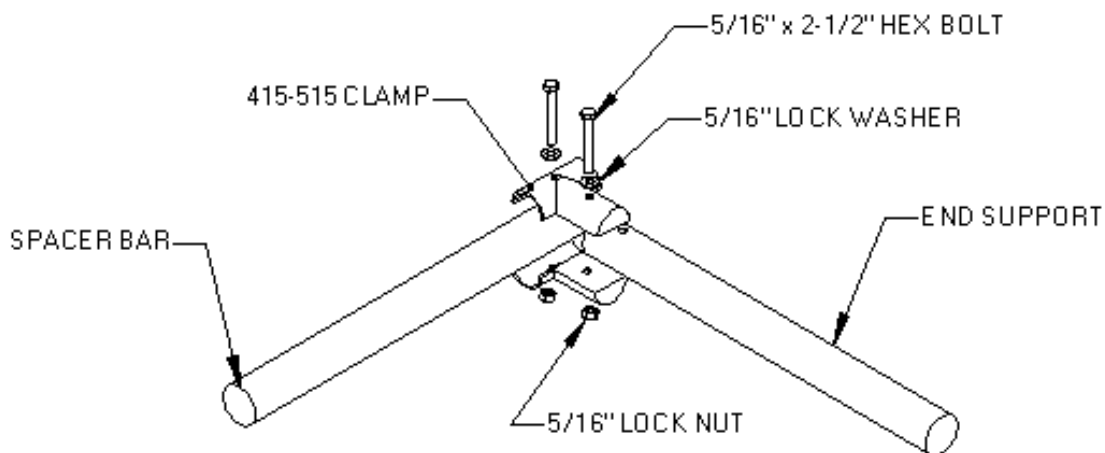

# 802-176 10' SINGLE SIDE BIKE RACK (Port)

## End Support and Spacer Detail:

