

802-178 20' SINGLE SIDE BIKE RACK (Port)

Page 1

Rev 03/21/03

I M P O R T A N T

Please retain this instruction sheet in your files. It contains important maintenance instructions, as well as replacement parts information.

PACKING LIST

1	CTN		Hardware Bag
1	BDL	2	803-268 Spacer Bar
1	BDL	2	803-267 End Support
1	WF	1	803-269 Center Support
1	WF	1	803-328 Ladder

HARDWARE BAG

4	116-514	5/16" x 3 1/2" Hex Bolt
12	116-510	5/16" x 2 1/2" Hex Bolt
16	326-501	5/16" Lock Washer
16	226-501	5/16" Lock Nut
6 pr	415-515	1 5/8" T-Clamp
14	105-015	1 5/8" Pipe Plug

1 CTN	2 BDLS	3 WF	6 TOTAL PCS	WT 150#	CLASS 70
-------	--------	------	-------------	---------	----------

802-178 20' SINGLE SIDE BIKE RACK (Port)

Page 2

Rev 03/21/03

GENERAL ASSEMBLY INSTRUCTIONS:

Check all the parts and hardware with the packing list too be sure you have received everything needed to assemble this product.

CONTACT YOUR LOCAL DISTRIBUTOR WITH NOTIFICATION OF ANY MISSING OR DAMAGED PARTS. Contact must be made within ten days of receipt of your order.

Only hand-tighten nuts & bolts on initial assembly. Final tightening should be done EVENLY after final assembly when unit has been plumbed & leveled.

After assembly is complete, ANY ENDS OF BOLTS PROTRUDING BEYOND NUTS SHOULD BE CUT OFF AND/OR PEENED OVER TO REMOVED ANY SHARP PROJECTIONS. Go over entire unit to file smooth any sharp edges or projections that may have been caused by rough handling in shipping or installation. T-Clamps are designed for both one and two bolt connections. In many situations only one bolt is required. See specific assembly instructions.

On products with platforms install 1-2 degrees off level to facilitate water drainage.

GENERAL MAINTENANCE INSTRUCTIONS:

Check MONTHLY for loose bolts, damaged or broken parts. Tighten and/or replace immediately.

- Step #1 Assemble bike rack as per drawing on page 1. Start by attaching #803-268 Spacer Bar to one end support and the center support.
- Step #2 Attach ladder to end supports using T-Clamps. The top of the center support slides over the top rail of the ladder. The bottom of the center support is attached with a T-clamp.
- Step #3 Attach other end of bike rack following same procedure.
- Step #4 Drive in pipe plugs on all open pipe ends.
- Step #5 Attach Anchor Bolts to end supports and place Bike Rack in position over footing holes.
- Step #6 Pour concrete. Wait 48 hours before using equipment.

802-178 20' SINGLE SIDE BIKE RACK (Port)

T-Clamp Detail:

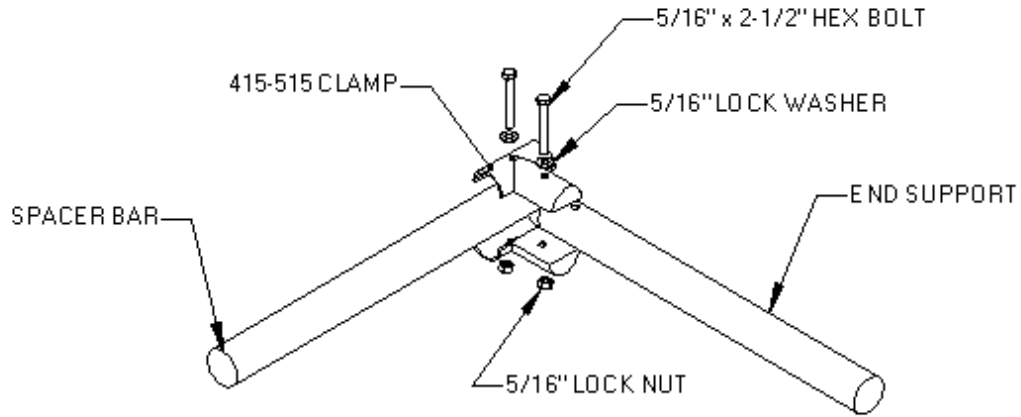

End Support and Spacer Detail:

