

**3-1/2" ARCHED SWING FRAME
8' FOUR BAY
#85043408XX**

USER GROUP: 2-12 years

RECOMMENDED CREW: 3 people

TOOLS REQUIRED:

- Clevis Key (supplied by manufacturer)
- Wheelbarrow
- Post Hole Digger / Shovel / Auger
- 1/4" Allen Head Wrench
- Level

CONCRETE REQUIRED: 28 cubic feet

NOTE: Concrete must have a minimum rating of 2,500 psi and must be mixed per manufacturer's recommendations.

INSTALLATION TIME: Approximately 3 hours

WEIGHT: 615 lbs.

**3-1/2" ARCHED SWING FRAME
8' FOUR BAY
#85043408XX**

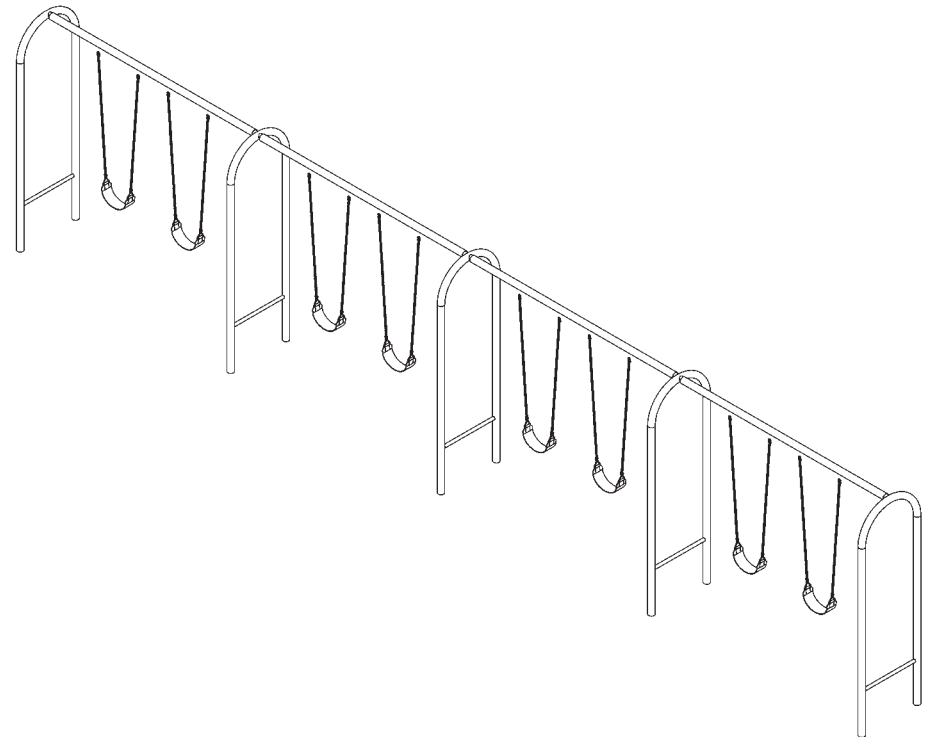

PRE-INSTALLATION CHECK:

Compare all items received to the packing list. Notify your local sales representative immediately if any parts are missing or damaged.

We are not responsible for items discovered missing after 72 hours from time of delivery!

Before beginning installation, make sure that you have read and understand the **Installation Introduction** manual that was supplied to you. If you did not receive a copy, or if you have a question regarding anything covered in this manual, contact your local sales representative.

STEP 1

Refer to PLAN VIEW and FOOTING LAYOUT to locate position of swing frame.

STEP 2

Excavate footing holes as shown in footing elevation and footing layout. Place a 2" spacer block in bottom of each hole.

STEP 3

Select two arched swing frame ends, four top bars, three swing frame middle sections and sixteen set screws. Set swing frame ends and swing frame middles into place in footing holes and brace into position. Attach top bars to swing frame middles and swing frame ends with swing hangers located at 6:00 then install and tighten set screws in top bars (see Detail A and B).

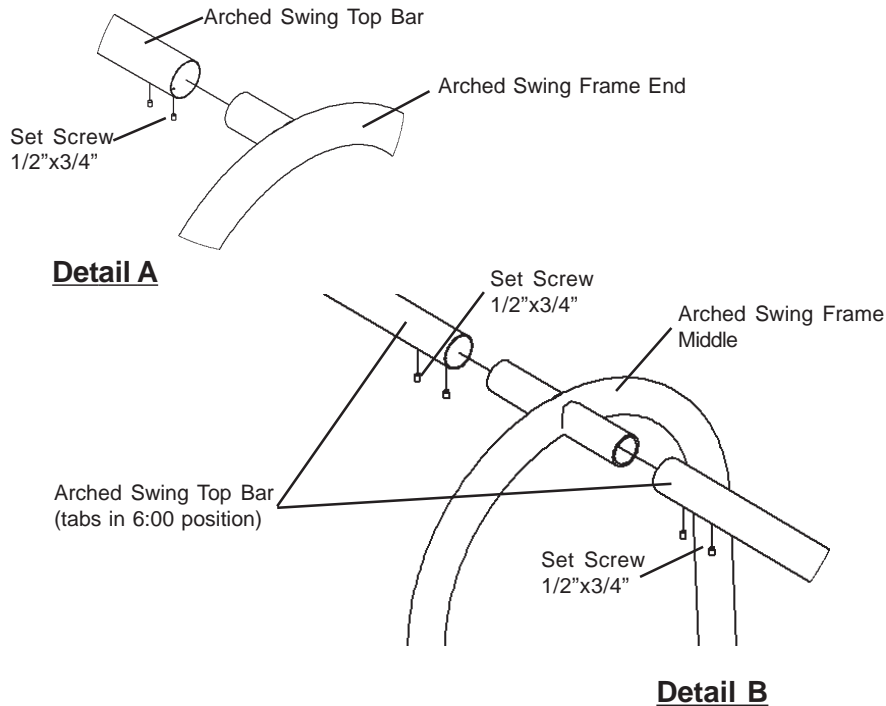

STEP 4

Verify that swing frame is level and plumb in footings and that it is at correct height. **NOTE:** Center of top rail needs to be 96" above finished surfacing. our concrete in footings to correct level.

NOTE: Concrete must have a minimum rating of 2,500 psi and must be mixed per manufacturer's recommendations. **Allow concrete to harden for at least 48 hours before use!** For safety reasons, do not attach swing chains or seats to swing frame until playground is ready to open. **NOTE:** Swing seats and chains sold separately.

**BILL OF MATERIALS
PART / HARDWARE LIST**

ITEM NO	QTY.	PART NO.	DESCRIPTION
1	4	90115203XX	2-3/8"x132" Top Bar for Arch Swing
2	2	30115201XX	3.5" Arch Swing Frame End
3	16	2080040392	Set Screw - 1/2" x 3/4" Allen Head
4	3	30115202XX	3.5" Arch Swing Frame Middle

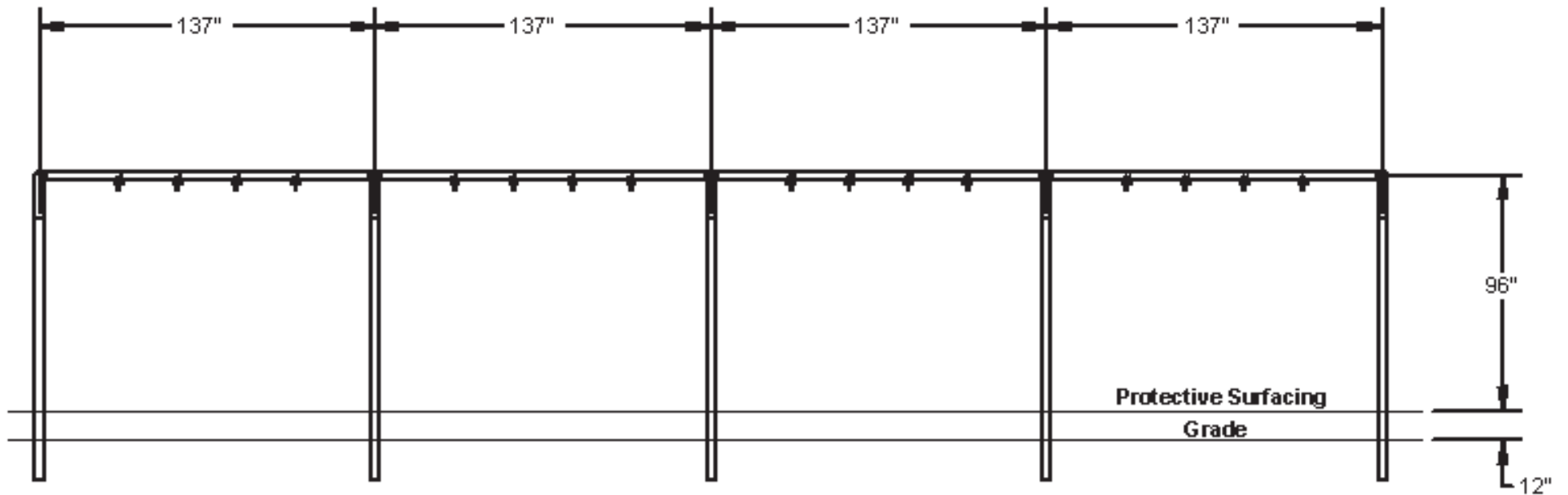

ELEVATION VIEW

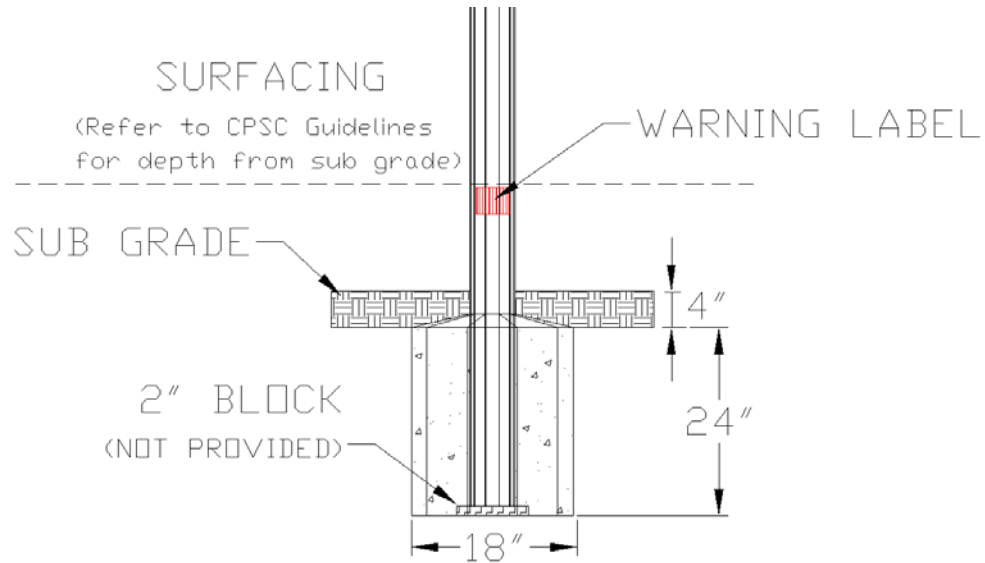

FOOTING ELEVATION

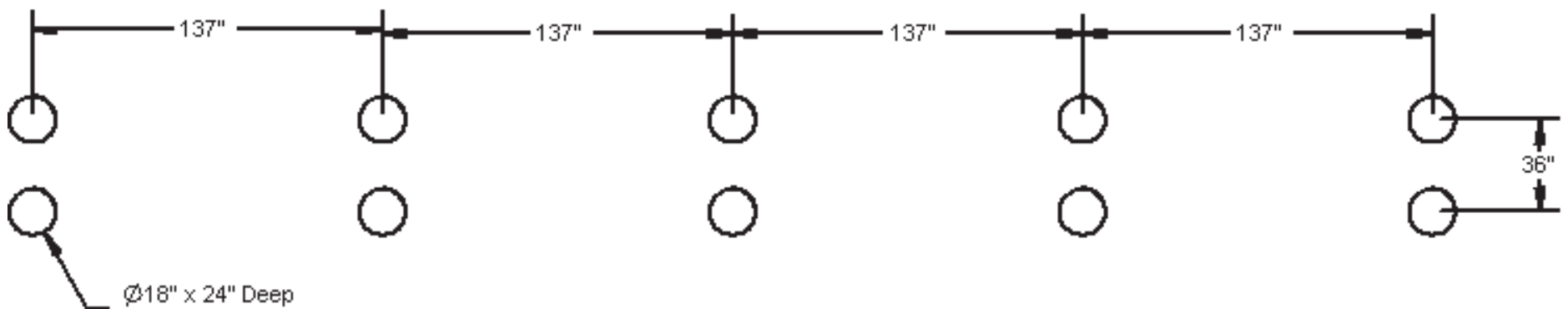

FOOTING LAYOUT

PRODUCT SPECIFICATIONS**SWING FRAME**

- 3-1/2" round steel tube
- 13 gauge steel
- Manufactured per ASTM 500
- 50,000 psi yield strength (ASTM E-8)
- 55,000 psi tensile strength (ASTM E-8)
- Triple Flo-Coated corrosion protection (interior and exterior)
- Interior and exterior corrosion resistance (ASTM B-117)
- Powder coat finish

TOP BAR

- 2-3/8" round steel tube
- 9 gauge steel
- Manufactured per ASTM 500
- 50,000 psi yield strength (ASTM E-8)
- 55,000 psi tensile strength (ASTM E-8)
- Triple Flo-Coated corrosion protection (interior and exterior)
- Interior and exterior corrosion resistance (ASTM B-117)
- Powder coat finish

SH-46 SWING HANGERS

- Grade 32510 hot-dipped, galvanized, malleable iron
- Rust-proof
- Manufactured per ASTM A339-55
- Lubrication-free brass bearing
- Smooth, noiseless action
- Welded to swing frame

PRETREATMENT WASH PRIMER

- 4860-420 primer / 1000-44 activator
- Polyvinyl-butyral resin based primer
- Used on all milled steel and all weld joints
- Designed to give adhesion to a wide variety of metal substrates
- Provides added metal protection against rust
- Imparts extra durability to topcoat (powder coat)
- When reduced properly, it meets the definition of a "pretreatment" primer found in many air quality regulations

POWDER COAT FINISH

- TGIC Polyester
- Electrostatic application
- Baked-on @ 400 degrees
- Lead free
- High gloss
- No peel / No flake finish
- Resistant to salt spray (ASTM B117)
- Resistant to humidity (ASTM D2247)
- Direct/Indirect impact 120 in. pounds (ASTM D2794)
- Good to excellent resistance to most solvents, oils, acids and alkalies
- 13 color options