

**FREESTANDING 36" 90° CURVE SLIDE
3-1/2" Vertical Posts**

**FREESTANDING 36" 90° CURVE SLIDE
#90008043XX**

USER GROUP: 2-12 years

RECOMMENDED CREW: 2 people

TOOLS REQUIRED:

T-30 TORX Tool (supplied by manufacturer)

3/16" Allen Head Wrench

Level

Shovel / Post Hole Digger / Auger

High Speed 3/8" Electric Drill w/clutch

NOTE: Use of any other driver on C-Line fittings may result in damage to tool and/or hardware!

CONCRETE REQUIRED: 19 cubic feet

WEIGHT: 550 lbs.

PRE-INSTALLATION CHECK:

Compare all items received to the packing list. Notify your local sales representative immediately if any parts are missing or damaged.

We are not responsible for items discovered missing after 72 hours from time of delivery!

Before beginning installation, make sure that you have read and understand the **Installation Introduction** manual that was supplied to you. If you did not receive a copy, or if you have a question regarding anything covered in this manual, contact your local sales representative.



INSTALLATION GUIDELINES

STEP 1

Refer to PLAN VIEW and FOOTING DIAGRAM to locate position of slide.

STEP 2

Excavate footing as shown in FOOTING ELEVATION and FOOTING DETAIL. Place a 2" spacer block in bottom of each hole.

STEP 3

Select two freestanding post and gate pieces. Place in footing holes and brace in position.

STEP 4

Select 36" square play deck, eight 3/8"x1" security TORX head bolts, sixteen 3/8" flat washers and eight 3/8" hex nuts. Hold deck in position. Attach deck to freestanding post and gate pieces by inserting bolt through washer, post and gate piece, deck, washer and into nut (see Detail A). **NOTE:** Four sets per side of deck.

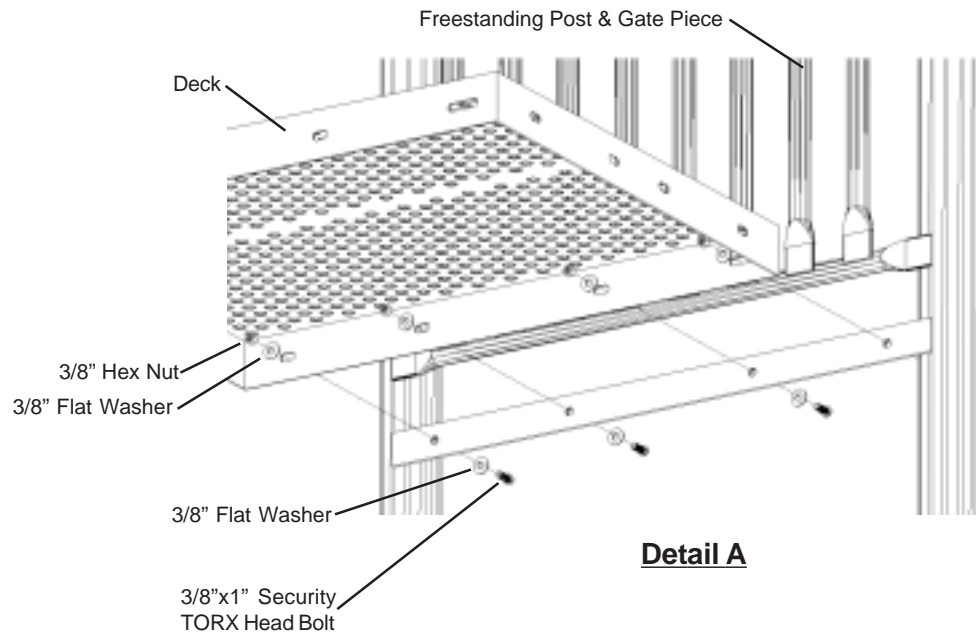

Detail A

STEP 5

Select two stair rails, two 3-1/2" component pipe clamps and two set screws. Attach pipe clamps to stair rails. Install and gently tighten set screws (see Detail B).

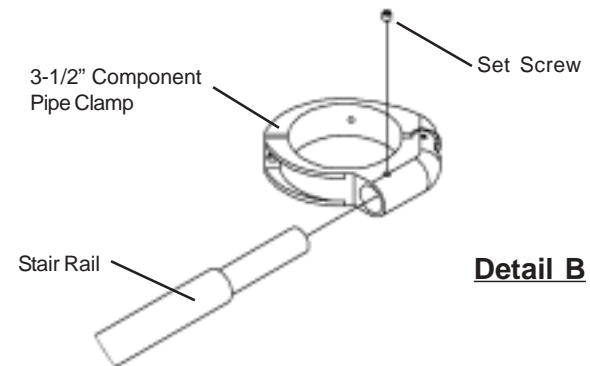

Detail B

STEP 6

Attach pipe clamps to post and gate assemblies. Install and gently tighten set screws (see Detail C).

Detail C

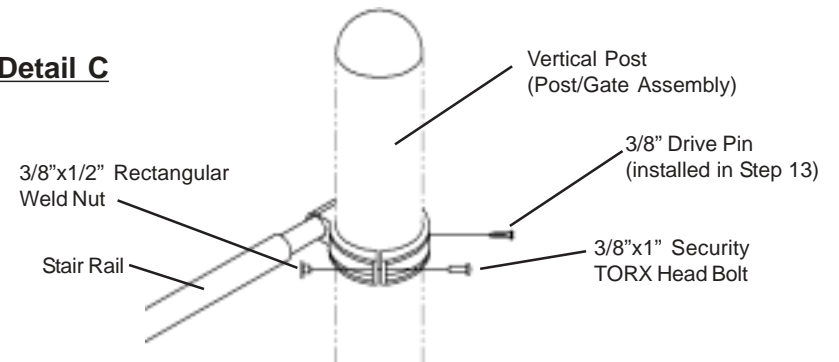

STEP 7

Select stairs and two 3/8" round weld nuts. Insert weld nuts in side holes in stairs. Tap into place. Set stairs in place. **NOTE:** End of stairs with four holes will mount to deck. Line up holes in stairs with holes in deck. Insert screwdrivers through two sets of holes in deck for temporary support.

STEP 8

Raise bottom of stair until stair and deck are flush and even.

STEP 9

Adjust handrails on vertical posts of post and gate assemblies until holes in handrails are aligned with holes in side of stairs.

STEP 10

Select two 3/8"x1-1/2" Security TORX head bolts. When holes in stairs are aligned with holes in rails, insert TORX head bolt through rail, stair and into weld nut (see Detail D). Tighten hardware.

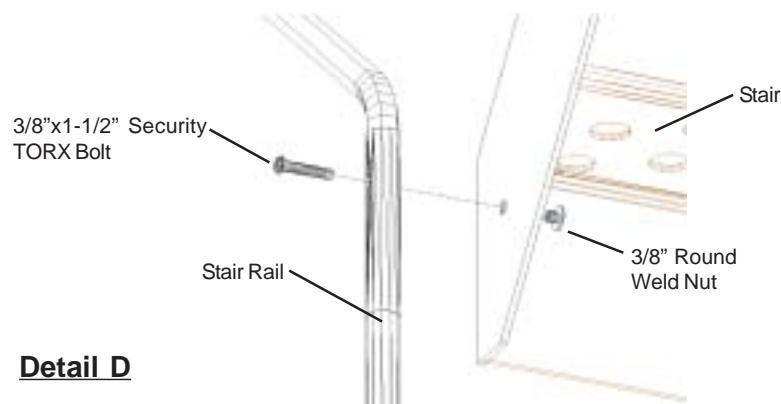

Detail E

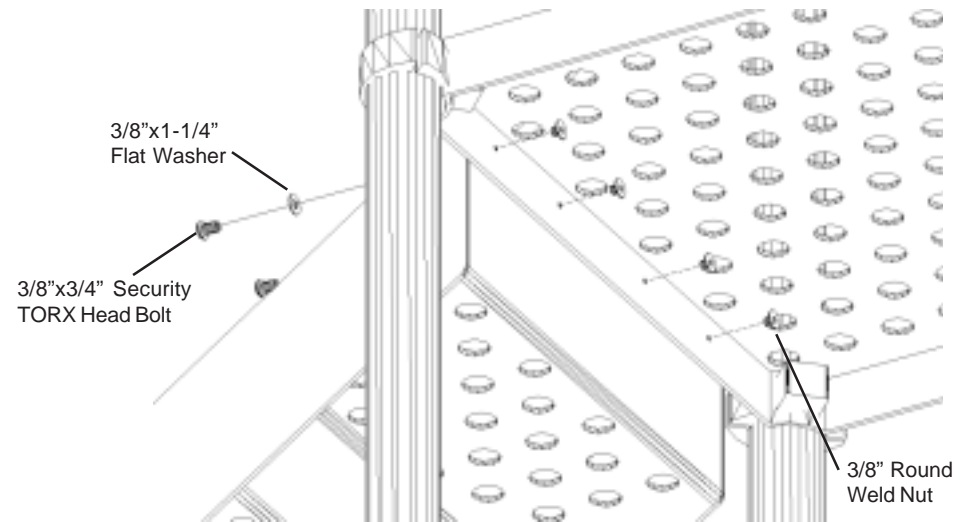

STEP 12

Verify that posts, deck and stairs are level and plumb. Tighten all hardware.

STEP 13

Select two drive pins. Drill one 1/4" hole through back side of each component clamp. Insert drive pin into hole. Tap into place (see Detail C).

INSTALLATION GUIDELINES

STEP 14

Select standard slide foot, four 3/8"x1" security TORX head bolts and four 3/8" flat washers. Attach slide foot to slide by inserting bolt through washer, slide foot and into slide (see Detail F). **NOTE:** Slide will be pre-drilled with threaded inserts installed. **OTE:** Slides are designed for specific standard deck heights (bottom of slide will be "X" number of inches from top of deck (ex: 36" slide will have a distance of 36" between top of deck and bottom of slide). If a "non-standard" deck height is being used, the standard distance from bottom of slide to top of deck must still be maintained.

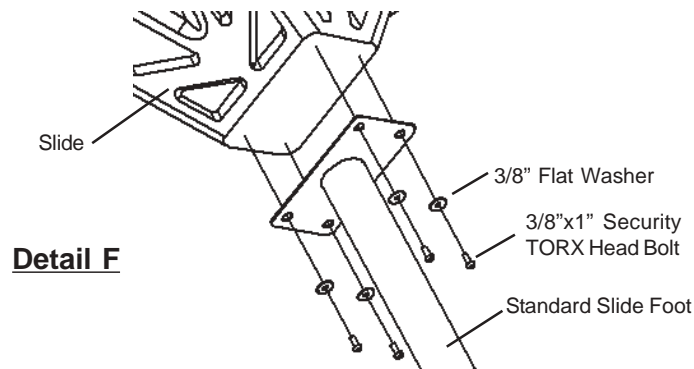

STEP 15

Select four 1/4" wafer bolts. Attach slide to deck by inserting wafer bolt through deck and into slide. **NOTE:** Slide will be pre-drilled with threaded inserts installed.

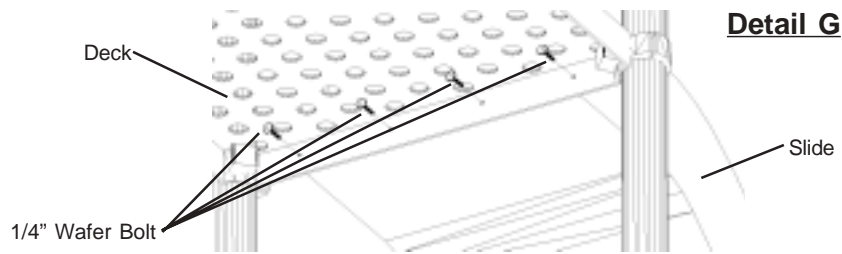

STEP 16

Select four adhesive gaskets for C-Line fitting and four 3-1/2" C-Line hood attachment fittings. Remove backing from one side of gasket and press on to back side of fitting. **NOTE:** Gasket is covered with a strong adhesive -- do not press on fitting until gasket is centered. Repeat process for remaining gaskets and fittings (see Detail H).

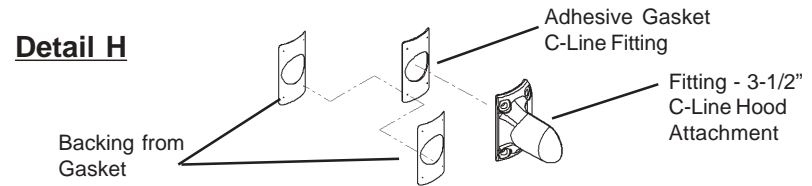

STEP 17

Select slide hood, four C-Line fittings with gaskets attached and four 1/4"x1-1/2" button head bolts. Attach fittings to slide hood as shown in Detail I. Remove backing from other side of gaskets.

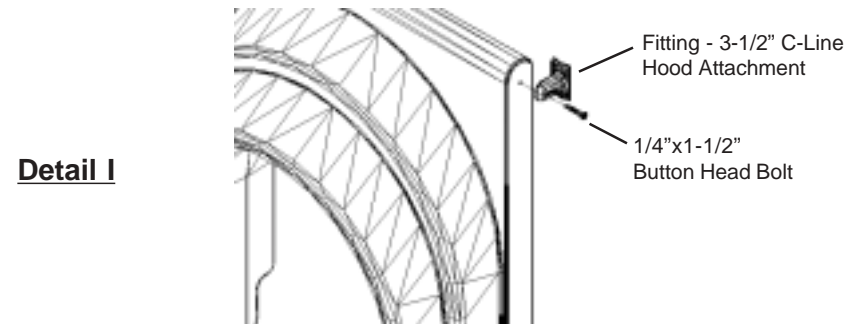

STEP 18

Select eight 1/4"x1" self tapping screws. Set slide hood in place. **NOTE:** Gasket is covered with a strong adhesive -- do not press on pipe until hood is centered, level and at correct height (bottom of slide hood will be even with top of deck). Install two self tapping screws in each fitting - only two holes of each fitting are accessible at this time (see Detail J). **NOTE:** Must use high speed 3/8" electric drill w/clutch. Use of any other driver may result in damage to tool and/or hardware.

INSTALLATION GUIDELINES

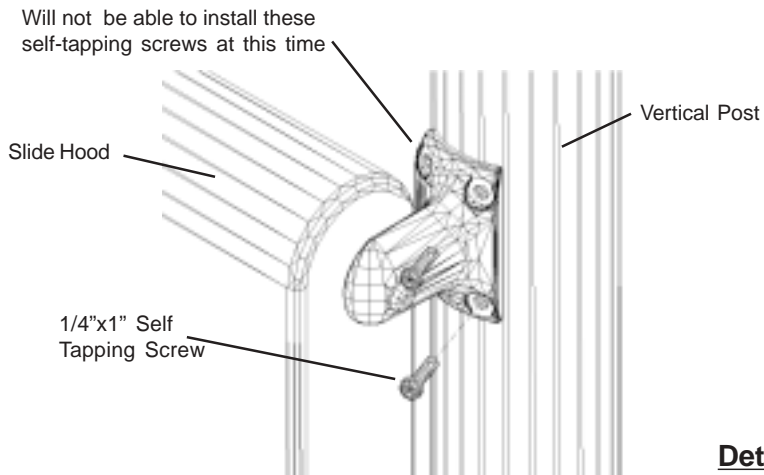

STEP 19

Detach hood from fittings. Install remaining two self tapping screws in each fitting. Gently tighten until both screws are installed. Then tighten all (see Detail K). **NOTE:** Must use high speed 3/8" electric drill w/clutch. Use of any other driver may result in damage to tool and/or hardware.

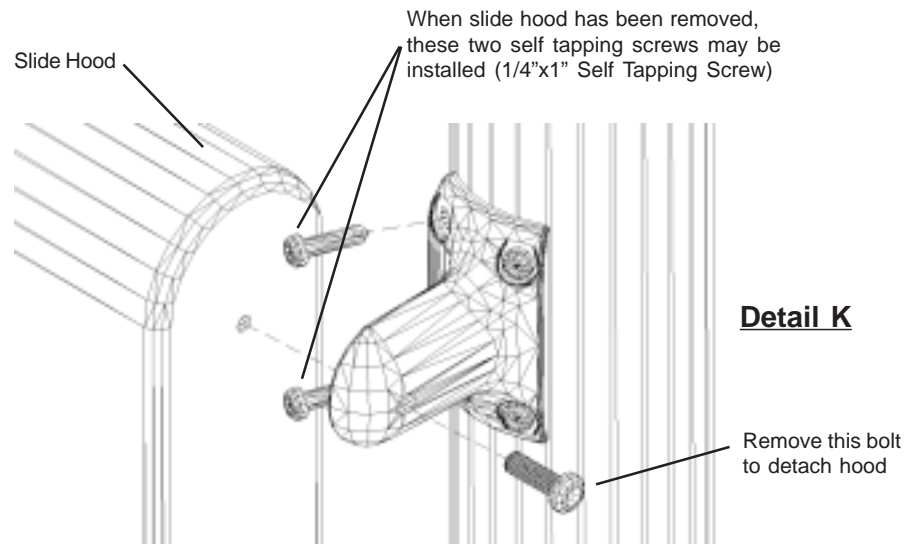

STEP 20

Reattach hood to fittings on all four corners as shown in Detail L.

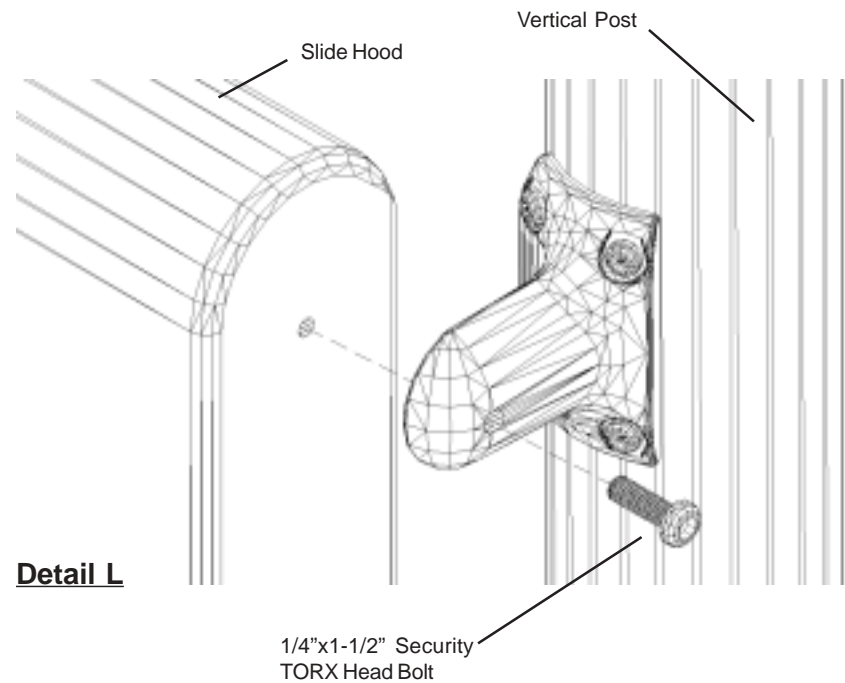

STEP 21

Ensure all hardware is secure and that slide and hood are level and plumb.

STEP 22

Pour concrete in footing to correct level. **Allow concrete to harden for at least 48 hours.**

FOOTING

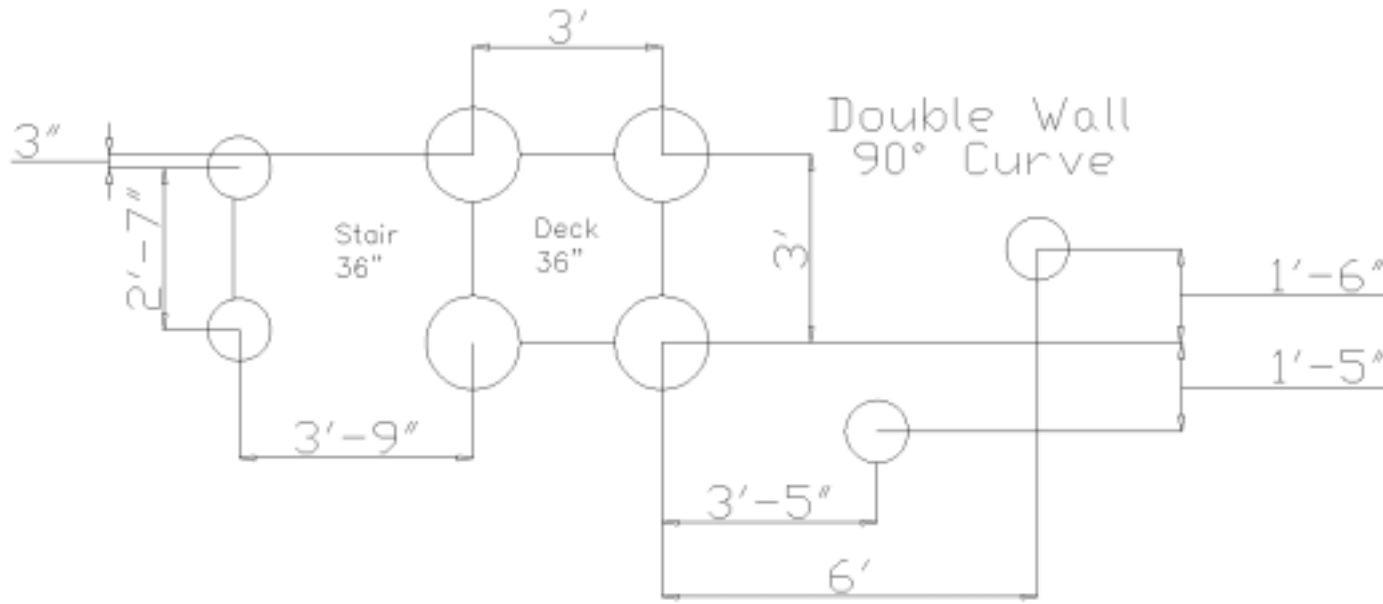

ELEVATION

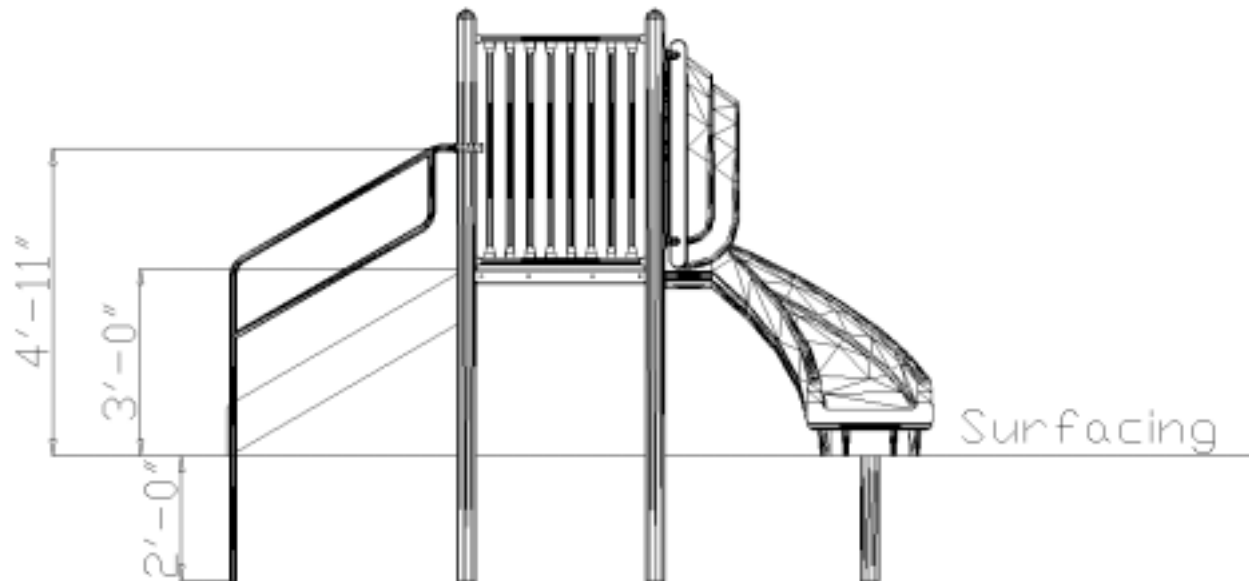

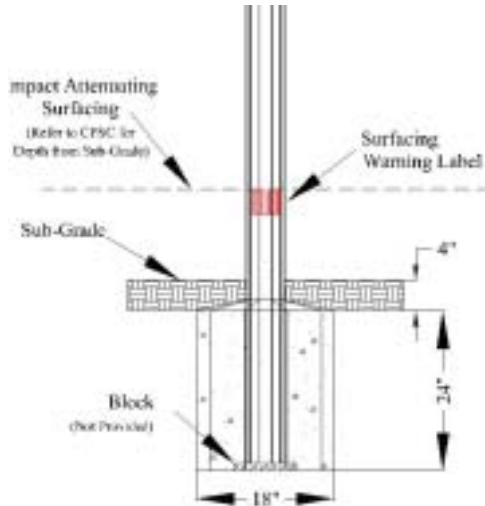

FOOTING ELEVATION - FREESTANDING POST AND GATE

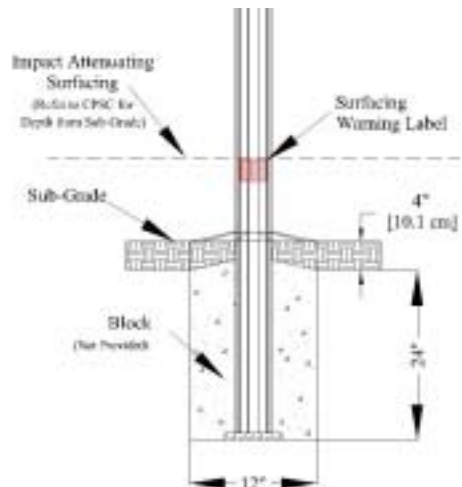

FOOTING ELEVATION - STAIR AND SLIDE FOOT

PRODUCT SPECIFICATIONS

HARDWARE

- Type 304 (18-8) stainless steel
- Conforms to ANSI/ASCE-8-90
- 84 ksi tensile strength
- 42 ksi yield strength
- Tamper resistant
- Special tool required for install
- Limited lifetime warranty

FITTINGS

- Aluminum alloy (GM70B) manufactured and tested in accordance with the following ASTM Standards: B179-68, B108-68, E10-66, E8-66
- Powder coat finish
- Predrilled
- Limited lifetime warranty

ADHESIVE GASKET

- Neoprene rubber
- 60 +/- 5 durometer hardness
- Double sided adhesive
- Limited lifetime warranty

PRODUCT SPECIFICATIONS**SLIDE / HOOD**

- 1st quality linear low density Polyethylene (ExxonMobil LL8450)
- Rotational molded
- 3/8" wall thickness
- 2,550 psi tensile strength (ASTM D638)
- UV stabilized
- Anti-static inhibitors
- 9 color options
- Limited 15-year warranty

SLIDE FOOT

- 3.5" O.D. support post
- 13 gauge galvanized steel support post
- 45,000 psi yield strength (ASTM E-8)
- 48,000 psi tensile strength (ASTM E-8)
- 12 gauge galvanized steel plate
- Triple Flo-Coated corrosion protection (interior/exterior)
- Interior and exterior corrosion resistance (ASTM B-117)
- Manufactured per ASTM 500
- Powder coat finish
- Limited lifetime warranty

PRETREATMENT WASH PRIMER

- 4860-420 primer / 1000-44 activator
- Polyvinyl-butyral resin based primer
- Used on all milled steel and all weld joints
- Designed to give adhesion to a wide variety of metal substrates
- Provides added metal protection against rust
- Imparts extra durability to topcoat (powder coat)
- When reduced properly, it meets the definition of a "pretreatment" primer found in many air quality regulations

POWDER COAT FINISH

- TGIC polyester
- Electrostatic application
- Baked-on @ 400 degrees
- 5-7 mills thick
- Lead free
- High gloss
- No peel / No flake finish
- Resistant to salt spray (ASTM B117)
- Resistant to humidity (ASTM D2247)
- Direct/Indirect impact 120 in. pounds (ASTM D2794)
- Good to excellent resistance to most solvents, oils, acids and alkalies
- 13 color options