

**SWING FRAME**  
**10' Four Bay Tri-Pod Swing Frame**  
**#90015314XX**

**USER GROUP:** 2-12 years

**RECOMMENDED CREW:** 3 people

**TOOLS REQUIRED:**

Shovel / Post Hole Digger / Auger

1/4" Allen Head Tool

Level

Tape Measure

String

**CONCRETE REQUIRED:** 84 cubic feet

**NOTE:** Concrete must have a minimum rating of 2,500 psi and must be mixed per manufacturer's recommendations.

**INSTALLATION TIME:** Approximately 4 hours

**WEIGHT:** 560 lbs.

**PRE-INSTALLATION CHECK:**

Compare all items received to the packing list. Notify your local sales representative immediately if any parts are missing or damaged.

**We are not responsible for items discovered missing after 72 hours from time of delivery!**

Before beginning installation, make sure that you have read and understand the *Installation Introduction* manual that was supplied to you. If you did not receive a copy, or if you have a question regarding anything covered in this manual, contact your local sales representative.

**10' FOUR BAY TRI-POD SWING FRAME**  
**#90015314XX**

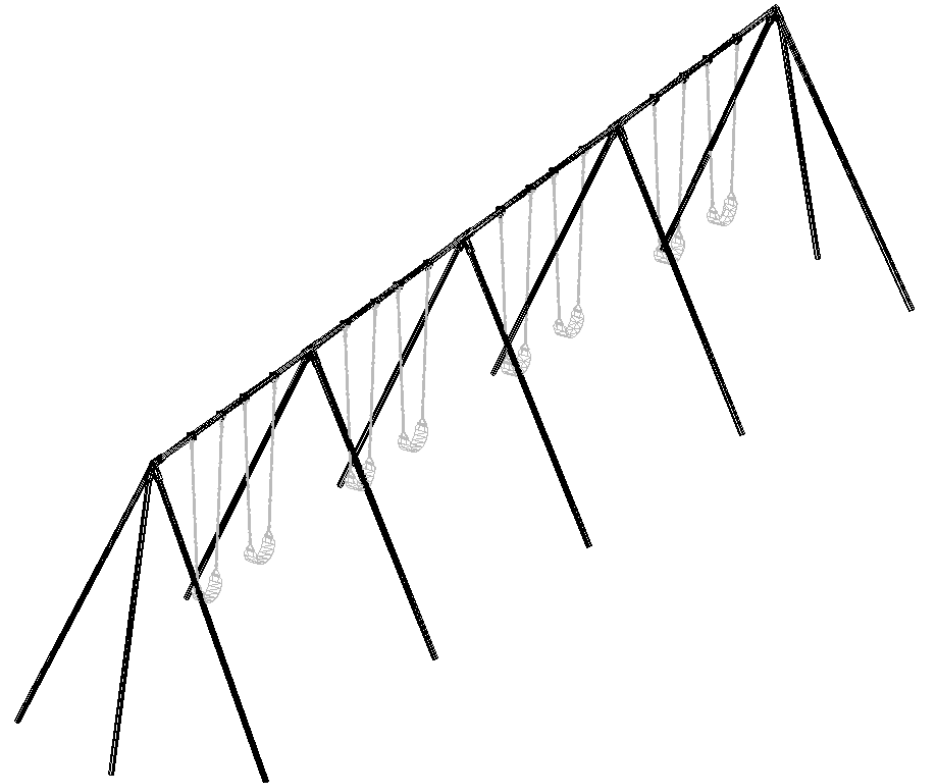

**NOTE:** Swing seats and chain are sold separately from swing frames. However, seats and chains are needed at time of installation to get correct measurements for swing hanger attachment.

## **STEP 1**

Refer to PLAN VIEW and FOOTING LAYOUT to locate position of swing frame.

## **STEP 2**

Excavate footing holes as shown in FOOTING ELEVATION and FOOTING LAYOUT Place a 2" spacer in bottom of each hole.

## **STEP 3**

Select end swing yokes, four swing legs (2-3/8"x144"), and two end swing leg (2-3/8"x135-15/16") with bent end. Assemble as shown in Detail A. **NOTE:** Bent end of swing leg must be installed in outermost leg of end swing yoke. Install and tighten set screws.

## **STEP 4**

Select middle swing yokes and remaining swing legs (2-3/8"x144"). Assemble as shown in Detail B. Install and tighten set screws.

## **STEP 5**

Set end yoke assembly and middle yoke assembly into footings. Hold in position.

## **STEP 6**

Select top rails (2-3/8"x132"). Insert top rail in each swing yoke (see Details A & B). Install and tighten set screws.

## **STEP 7**

For each bay, select four swing hanger assemblies (SH-09's). Attach SH-09's to top rail so that center of SH-09's for each swing are at least 20" apart. **NOTE:** All other side to side measurements will need to be set and verified after swing seats are installed (swing seats and chains are sold separately). Measure up 60" from top of finished surfacing. Run string line from end to end of swing frame at this height. The horizontal distance between adjacent to-fro swings at rest shall be no less than 24" when measured at 60" above the protective surfacing. The horizontal distance between the supporting structure and the adjacent to-fro swing seat shall be no less than 30" when measured at 60" above the protective surfacing. Also, once seats are installed, they must be at least 12" above the finished surfacing (see Detail C and SWING DETAIL on Page 3). **NOTE:** All of these measurements need to be taken when swings are occupied by maximum users. Please see Page 3 for detail drawings of critical dimensions.

### **Detail A**

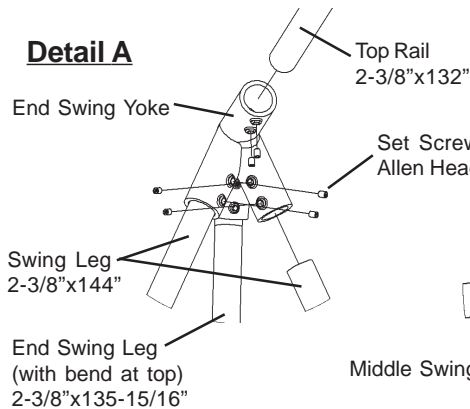

### **Detail B**

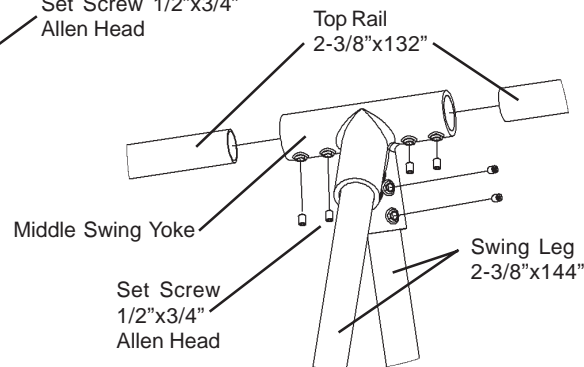

### **Detail C**

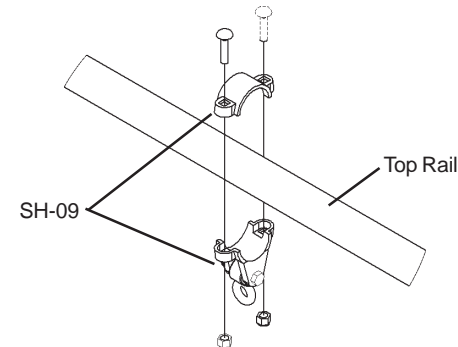



**STEP 11**

Block and brace swing frame to correct height and make sure that swing frame is level and plumb. **NOTE:** Center of top rail needs to be 120" above finished surfacing. Pour concrete in footings to correct level. **NOTE:** Concrete must have a minimum rating of 2,500 psi and must be mixed per manufacturer's recommendations. **Allow concrete to harden for at least 48 hours before use.** For safety reasons, do not attach swing chains or seats to swing frame until playground is ready to open. **NOTE:** Swing seats and chains sold separately.

**BILL OF MATERIALS  
PART / HARDWARE LIST**

<b>ITEM NO.</b>	<b>QTY.</b>	<b>PART NO.</b>	<b>DESCRIPTION</b>
1	4	90115401XX	Fab - 2-3/8"x132" Swing Top Rail
2	2	98215402XX	Swing Yoke - Tri Pod End Casting
3	2	90115391XX	Fab-2-3/8"x14' Swing End Leg w/Bend
4	10	90115390XX	Fab - 2-3/8" x 14' Swing Leg
5	16	9001550991	2-3/8" Swing Hanger Assembly (SH-09)
6	3	98215401XX	Swing Yoke - Bi & Tri Pod Mid Casting

# INSTALLATION GUIDELINES

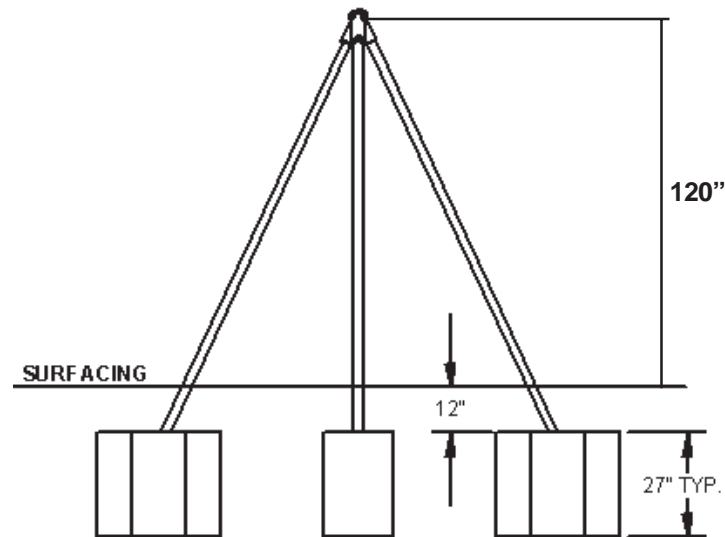
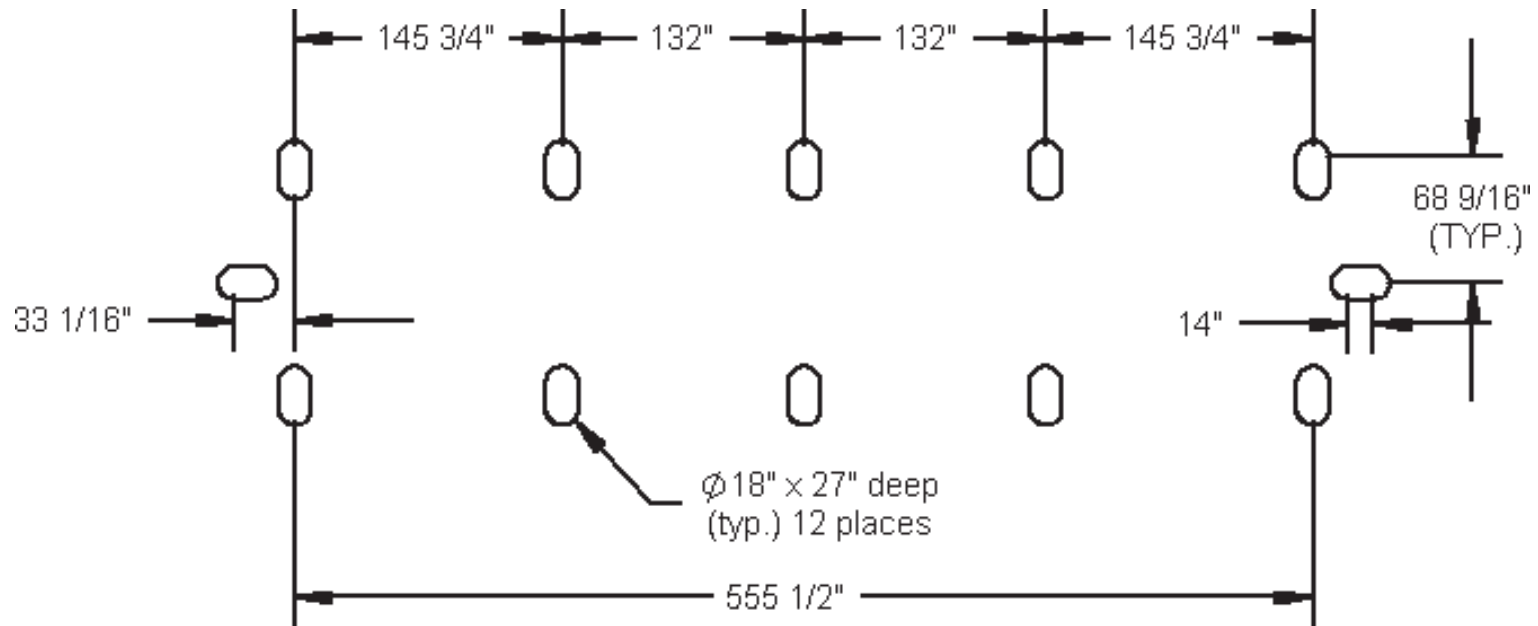

FOOTING DETAIL

## **PRODUCT SPECIFICATIONS**

### **SH-09**

- Grade 32510 galvanized stamped ductile iron
- 60,000-120,000 psi tensile strength (ASTM A339-55)
- 40,000-90,000 psi yield strength (ASTM A339-55)
- Smooth, noiseless operation
- Will not twist on pipe
- Lubrication-free nylon bearing

### **SWING YOKE**

- 356 Aluminum alloy
- Heat treated to T-6 specifications
- 30.0 ksi tensile strength
- 20.0 ksi yield strength
- Powder coat finish

### **PRETREATMENT WASH PRIMER**

- 4860-420 primer / 1000-44 activator
- Polyvinyl-butyril resin based primer
- Used on all milled steel and all weld joints
- Designed to give adhesion to a wide variety of metal substrates
- Provides added metal protection against rust
- Imparts extra durability to topcoat (powder coat)
- When reduced properly, it meets the definition of a “pretreatment” primer found in many air quality regulations

### **HARDWARE**

- Tamper resistant
- Special tool required for install

### **SWING FRAME (TOP RAIL & LEG)**

- 2-3/8” round galvanized steel tube
- 9 gauge steel (top rail)
- 13 gauge steel (leg)
- Manufactured per ASTM 500
- 50,000 psi yield strength (ASTM E-8)
- 55,000 psi tensile strength (ASTM E-8)

### **POWDER COAT FINISH**

- TGIC Polyester
- Electrostatic application
- Baked-on @ 400 degrees
- 5-7 mills thick
- Lead free
- High gloss
- No peel / No flake finish
- Resistant to salt spray (ASTM B117)
- Resistant to humidity (ASTM D2247)
- Direct/Indirect impact 120 in. pounds (ASTM D2794)
- Good to excellent resistance to most solvents, oils, acids and alkalis