

**WHALE SPRING RIDER
#90018201XX**

Installation Time: 1-1/2 hours (over a 2-day period)
Concrete Required: 3-1/2 cubic feet
Weight: 90 Pounds

REQUIRED TOOLS:

Shovel / Post Hole Digger / Auger
Wheelbarrow
Concrete Trowel
Level
T-45 TORX Tool (supplied by manufacturer)
Heavy cardboard for 18" diameter X 24" round concrete form (sonotube)
Template for J-Bolts (20"x20") with 4 holes in center spaced 6" apart in square pattern.
(May be made from heavy cardboard, plywood, particle board, etc.)

PRE-INSTALLATION CHECK

Compare all items received to the packing list. Notify your local sales representative immediately of any missing or damaged parts.

We are not responsible for items discovered missing after 72 hours from time of delivery!

Before beginning installation, make sure you have read and understand the Installation Introduction manual that was supplied to you. If you did not receive a copy, or if you have a question regarding anything covered in this manual, contact your local sales representative.

USE ZONE

The use zone for rocking/springing equipment upon which the user is intended to sit shall be no less than 72" (1830 mm) in all directions from the at-rest perimeter of the equipment. The use zones of adjacent rocking/springing equipment intended for sitting may overlap when each structure consists of a seat or designated play surface with a height of 30" (760 mm) or less above the protective use zone surfacing when unoccupied. Use zone overlaps vary when structures other than riders are adjacent.

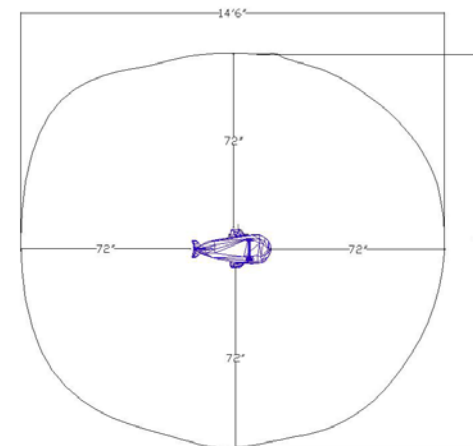

STEP 1:

Select template for J-Bolts, four 12" long J-Bolts, eight 1/2" washers and four 1/2" nuts. Attach J-Bolts to template by inserting J-Bolt through washer, template, washer and into nut. Adjust so all are level and the same amount is protruding through the top of the template. See Detail A.

Detail A

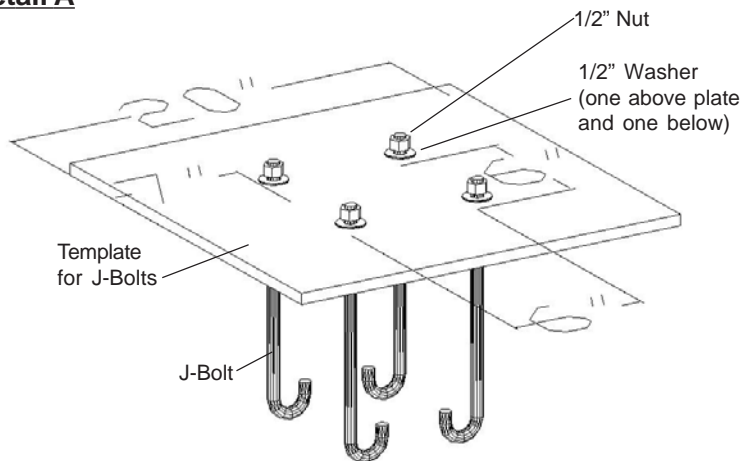

STEP 2:

Excavate footing hole as shown in FOOTING ELEVATION. Use heavy cardboard to create a mold or sonotube for the concrete (18" diameter by 24" high). Place the sonotube in the hole.

STEP 3:

Excavate footing hole as shown in FOOTING ELEVATION. Use heavy cardboard to create a mold or sonotube for the concrete (18" diameter by 24" high). Place the sonotube in the hole.

STEP 4:

Fill the hole and form with concrete until it reaches top of tube. Bevel top edge of concrete to eliminate sharp corner. Press J-Bolts into concrete, leaving a 1" gap between the underside of the jig and the concrete.

Allow concrete to harden for 24 hours before continuing assembly.

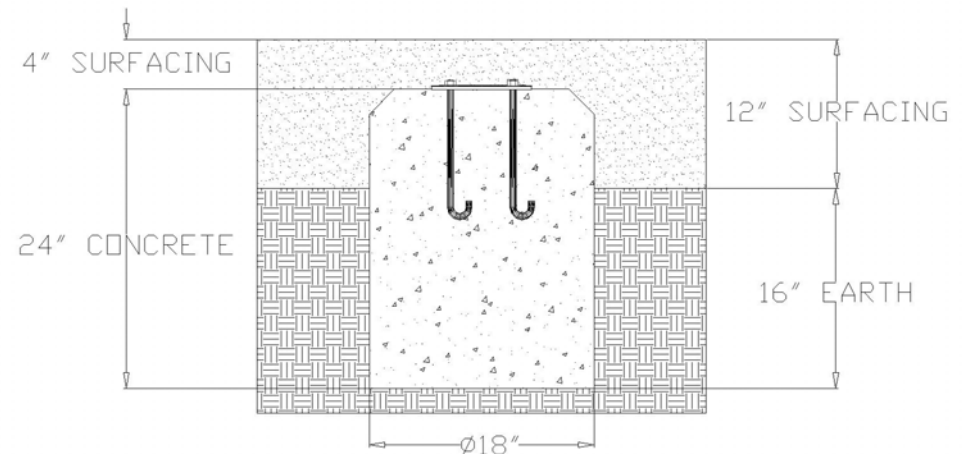

Footing Elevation

NOTE: Footing Elevation shown with 12" of surfacing and 8" of concrete above grade. The height of your concrete above grade will vary depending on your surfacing depth. **You must maintain 4" of surfacing above base plate and 24" of concrete in ground. Also, seat height of rider must be between 14" and 28" above finished surfacing.**

INSTALLATION GUIDELINES

BILL OF MATERIALS

ITEM #	QTY.	PART NO.	DESCRIPTION
1	1	10018002XX	Coil Spring w/Flat Plate
2	1	SA-04	Whale Spring Rider
3	1	HK-JBOLT	J-Bolt Mounting Hdwe.
4	4	2080011192	3/8"x1" TORX Head Bolt
5	4	2090010292	Hand Key T-45 Security

STEP 5:

Select rider, spring assembly, four 3/8"x1" TORX head bolts and four 3/8"x1-1/4" flat washers. Align holes in top plate with holes in rider.

NOTE: The end plate with the largest holes will attach to the rider - plate with smallest holes attaches to concrete. Attach spring to rider by inserting bolt through washer and into rider. Gently tighten until all hardware is installed - then tighten all.

STEP 6:

Detach template from concrete. **NOTE:** Installer may choose to provide four additional 1/2" nuts to install on J-Bolts before rider is attached to act as leveling nuts. Slide holes in base plate over J-bolts in concrete and install and tighten nuts on top of base plate.

STEP 7:

Select rider assembly. Align holes in bottom plate with J-bolts in concrete. Set rider in place. Secure rider to concrete using hardware removed in Step 6. Gently tighten until all hardware is installed. Then tighten all. **NOTE:** May have to use leveling nuts or shims under bottom plate to level rider.

*NOTE: All hardware supplied in bag may not be required for this assembly.

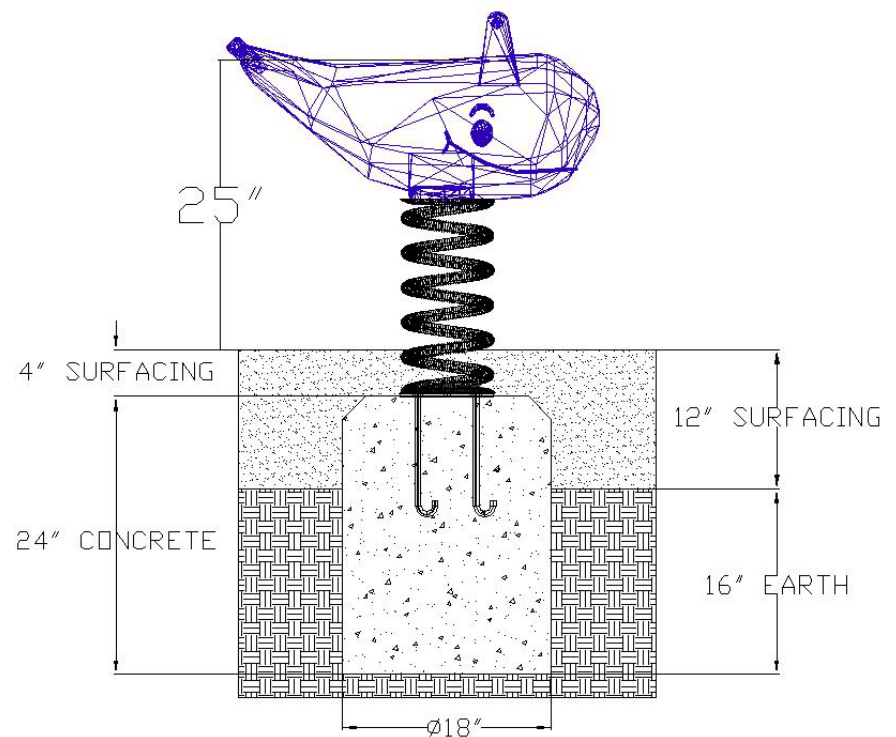

ELEVATION VIEW

PRODUCT SPECIFICATIONS

RIDER BODY

- 1st quality linear low density Polyethylene (ExxonMobil LL8450)
- Rotational molded
- 3/8" wall thickness
- 2,550 psi tensile strength (ASTM D638)
- UV stabilized
- Anti-static inhibitors
- 9 color options

SPRING ASSEMBLY

- 5160 H steel alloy
- Carbon Chromium grade of spring steel
- 5-3/4" O.D. spring
- 13/16" O.D. bar
- Black powdercoat finish

HARDWARE

- Type 304 (18-8) stainless steel
- Conforms to ANSI/ASCE-8-90
- 84 ksi tensile strength
- 42 ksi yield strength
- Tamper resistant
- Special tool required for install

PRETREATMENT WASH PRIMER

- 4860-420 primer / 1000-44 activator
- Polyvinyl-butylal resin based primer
- Used on all milled steel and all weld joints
- Designed to give adhesion to a wide variety of metal substrates
- Provides added metal protection against rust
- Imparts extra durability to topcoat (powder coat)
- When reduced properly, it meets the definition of a "pretreatment" primer found in many air quality regulations

POWDER COAT FINISH

- TGIC Polyester
- Electrostatic application
- Baked-on @ 400 degrees
- 5-7 mills thick
- Lead free
- High gloss
- No peel / No flake finish
- Resistant to salt spray (ASTM B117)
- Resistant to humidity (ASTM D2247)
- Direct/Indirect impact 120 in. pounds (ASTM D2794)
- Good to excellent resistance to most solvents, oils, acids and alkalis
- 13 color options