

## **FUNHOOP Assembly Instructions:**

Please read and follow all **Safety Information**.

- Please review assembly and component **Diagrams**.
- Verify **component & hardware** quantities received.
- Familiarize yourself with the **installation procedures**.

### **Safety**

- Play site ground material should only be of an approved, shock-absorbing type and meet minimum depth requirements. **NEVER** install playground equipment over paved or hard surfaces.
- Be sure that minimum fall zone requirements are met.
- Do not allow children to play on or near equipment which is in need or repair or replacement, is incomplete or is otherwise considered unsafe.

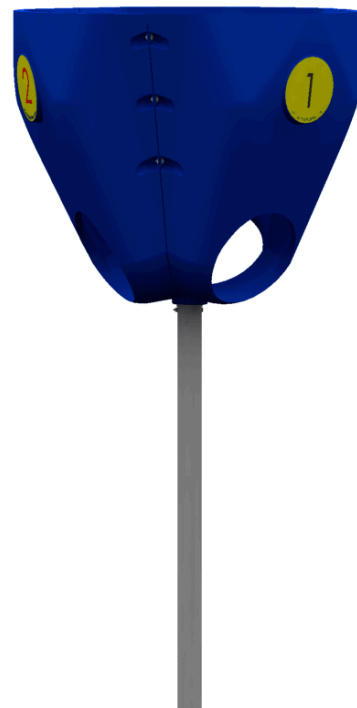

### **Parts Inventory and Set-Up**

Confirm that all components and hardware are included (see **Parts List**).

Gather any addition tools necessary for installation (wrench, level, tape measure, etc)

Please follow diagrams and instructions in order.

#### 1) **Site location and Preparation**

Be sure site is of adequate size- allow for minimum fall zones (see **Layout Diagram**).

Be sure site is graded, level and free of debris for proper set-up and assembly..

Measure and mark site to determine structure location and orientation.

#### 2) **Assembly- General**

Please use correct type and length fastener as shown in the installation procedure.

Be sure to follow the assembly order to ease the construction procedure.







#### 3) **Installation Procedure**

After measurement and layout of site, carefully measure for footer location.

Confirm footer location- dig, pour and set footer as described in instructions.

**PARTS LIST**

**Hardware Components:**

<b>Item</b>	<b>Qty.</b>	<b>Description</b>	<b>Drawing</b>	<b>Part Number</b>
HA	(9)	5/16"-18 x 3/4" T6L SS w/ Patch		100-51634
HB	(18)	5/16" FW X 3/4 OD .045 Thk SS		100-516FW
HC	(9)	5/16" Stainless Nylon Lock Nut		100-516NLSS
HD	(3)	1/4" 2.5" T-40 SS Self Tapping		100-1425ST
HE	(1)	Torx Bit 3/16" T40 Short Arm		100-00T40SA
HF	(1)	Drill Bit, 3/16" 118 Point		100-DB3/16

**Steel Component:**

SA	(1)	2 7/8" dia. galvanized pole		100-00004
----	-----	-----------------------------	--	-----------

**Plastic Component:**

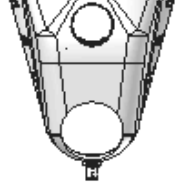
PA	(3)	1/3 FunHoop Shell		120-00015
----	-----	-------------------	---	-----------

PB	(3)	Numbered Sticker		
----	-----	------------------	---	--

**Layout Diagram**

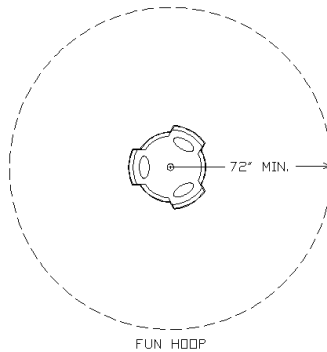

**NOTE: Overhead views are for planning purposes only.  
Please follow guidelines as specified by the CPSC and ASTM F1487.**

**Installation procedure:**

1) Assemble the (3) Funhoop shells (PA) together using the following: (HA) 5/16"-18 x 3/4" T6L SS w/ Patch, (HB) (6ea) 1/2" Flat Washer, and (HC) 5/16" Stainless Nylon Lock Nut at each connecting side.

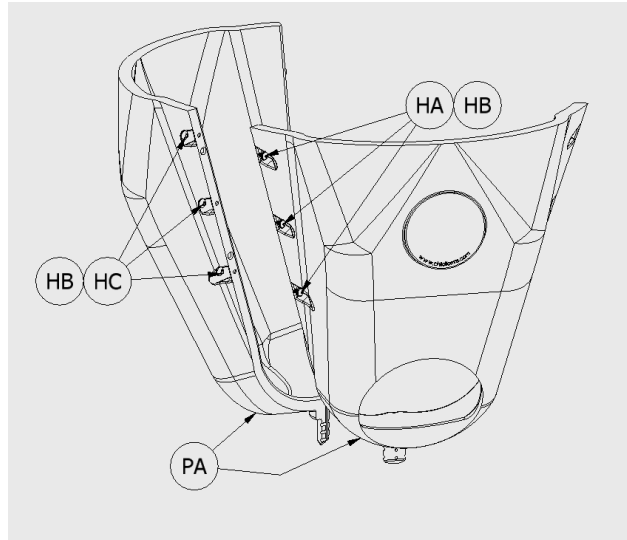

2) Apply the yellow adhesive number stickers (PB) in ascending order to the blue flat circles on each FunHoop shell around the FunHoop assembly. (Make sure surface is clean and dry)

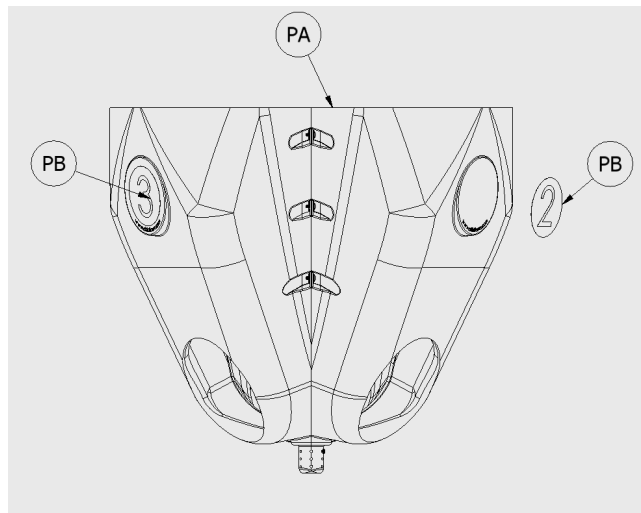

3) Insert Funhoop Assembly into the Vertical Pole (SA). (If necessary, use a hose clamp to squeeze the three parts together once in pole remove hose clamp), slide assembly all the way down until it bottoms out on the pole. Rotate until the ball exit holes align with the 3 pre-drilled holes in the pole. Using the holes in the pole as your guide. Drill (3) 3/16" x (1"-1.5"deep) pilot holes into the plastic. Use the 1/4" x 2.5" T-40 SS Self Tapping screws (HD) to secure pole to the Funhoop (See diagram).

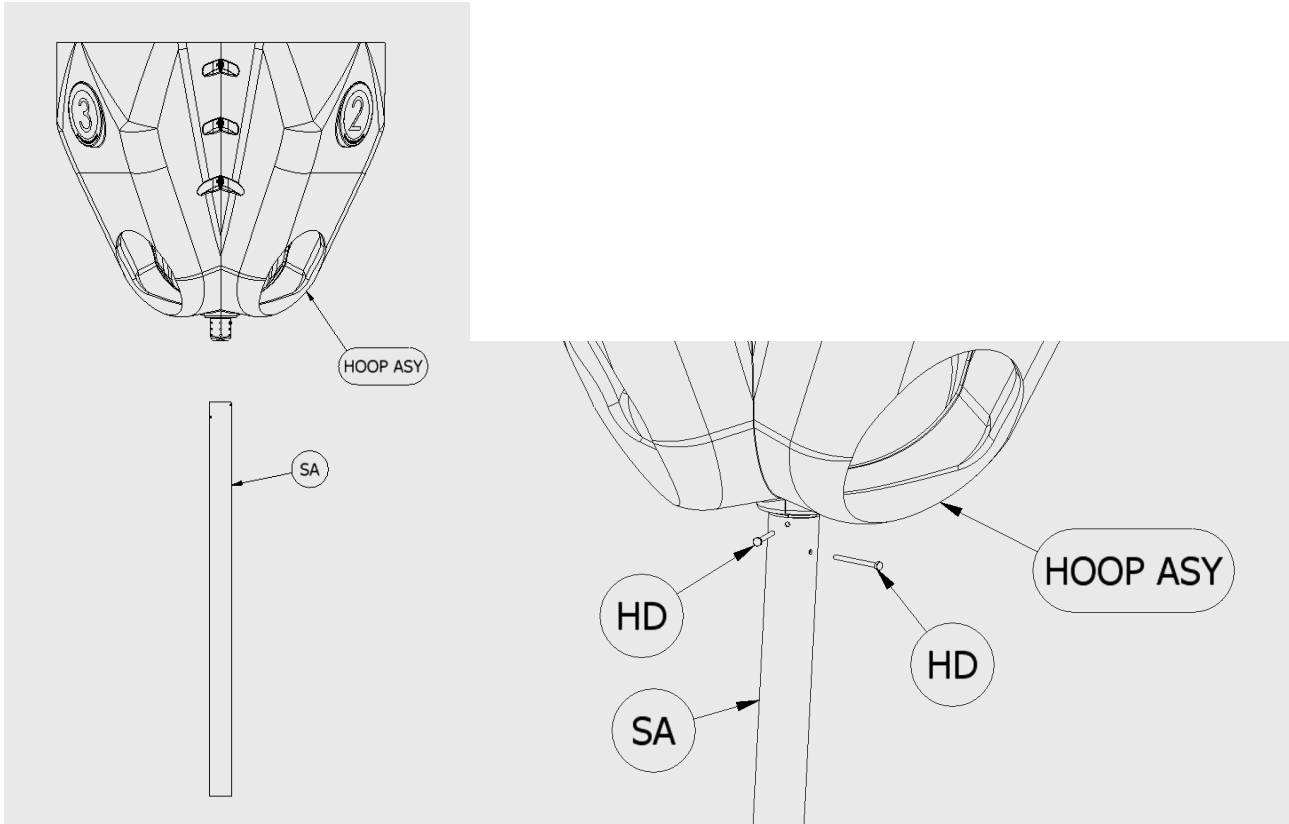

**Step 3-Pole mounting detail**

4) When you are ready to mount the Funhoop into the ground, determine the location, measure and dig hole approx. 18” diameter by 24” deep. This depth makes the top of the Funhoop 9’. For shorter heights you can deepen the hole, or cut length off of the pole; bottom Mix and pour concrete into hole, leaving concrete 2” below ground level. With assistance, lower the Funhoop assembly into the concrete- securely prop Funhoop assembly with wood or similar temporary bracing structural material.

5) Be sure Vertical Pole is plumb and square to ground. Let Funhoop assembly remain undisturbed for (3) days minimum- until concrete has fully set. Do not allow play on or around site during this time.

6) Finally, cover exposed concrete with dirt and tamp to ground level.

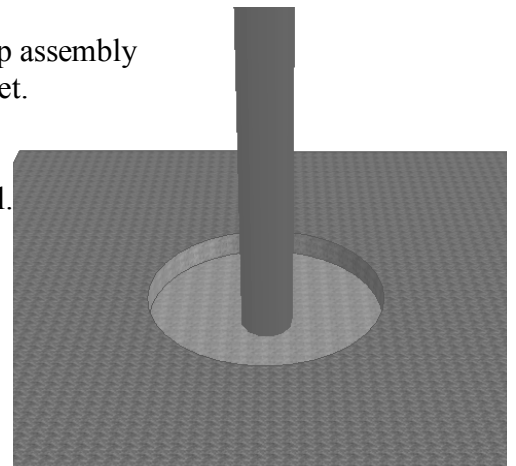

Rev	Date	Init.	Remarks
A	12-30-08	JEL	Originated