

**LOG ROLL - FREESTANDING  
#TFR03411XX  
3-1/2" Vertical Posts**

**USER GROUP:** 5-12 years

**RECOMMENDED CREW:** 1 person

**TOOLS REQUIRED:**

T-30 TORX Tool (supplied by manufacturer)

T-45 TORX Tool (supplied by manufacturer)

3/16" Allen Head Wrench

High Speed 3/8" Electric Drill *w/clutch*

**NOTE:** Use of any other driver may result in damage to tool and/or hardware!

**INSTALLATION TIME:** Approximately 1 hour

**WEIGHT:** 165 lbs.

**CONCRETE REQUIRED:** 7.06 Cubic Feet

**NOTE:** Concrete must have a minimum rating of 2,500 psi and must be mixed per manufacturer's recommendations.

**PRE-INSTALLATION CHECK:**

Compare all items received to the packing list. Notify your local sales representative immediately if any parts are missing or damaged.

**We are not responsible for items discovered missing after 72 hours from time of delivery!**

Before beginning installation, make sure that you have read and understand the ***Installation Introduction*** manual that was supplied to you. If you did not receive a copy, or if you have a question regarding anything covered in this manual, contact your local sales representative.

**LOG ROLL - FREESTANDING  
#TFR03411XX**

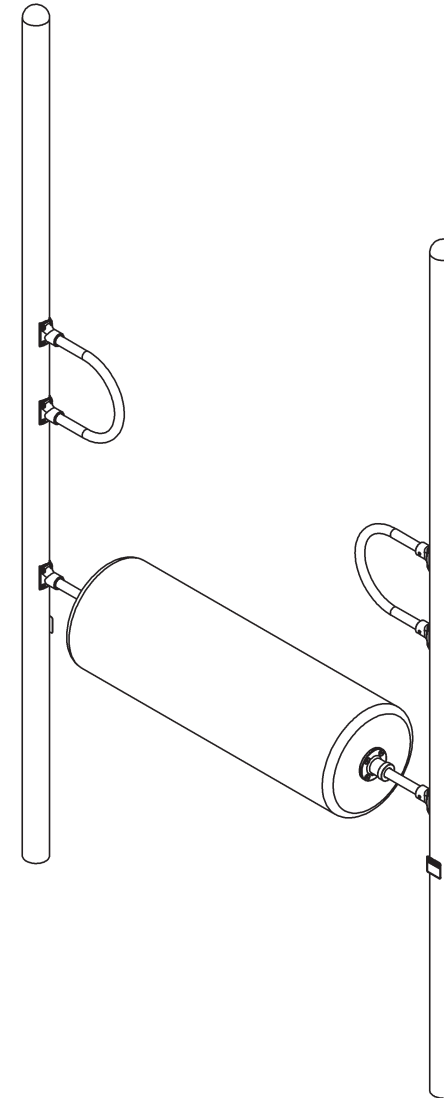

## STEP 1

Refer to PLAN VIEW and FOOTING LAYOUT to locate position of log roll. Excavate footing holes as shown in FOOTING ELEVATION and FOOTING LAYOUT. Place a 2" spacer in bottom of each hole. Set vertical posts in hole and block and brace into position.

## STEP 2

Select six C-Line pipe fittings and six sealing gaskets for C-Line fittings. Remove backing from one side of gasket and press on to back side of fitting (see Detail A). **NOTE:** Gasket is covered with a strong adhesive -- do not press on fitting until gasket is centered. Repeat for other gaskets and fittings.

### Detail A

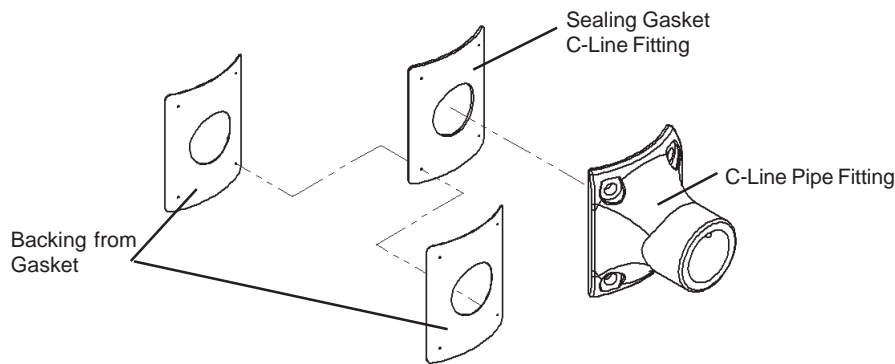

## STEP 3

Select two C-Line fittings with gaskets attached and log roll assembly. Slide fittings over end pipes of log roll as shown in Detail B. Remove backing from other side of fittings. Place log roll in position, making sure that it is level and that center of fitting is 9" above finished surfacing (see ELEVATION DETAIL on Page 3). Press fitting on to vertical post (see Detail B). **NOTE:** Gasket is covered with a strong adhesive -- do not press into place until log roll is positioned correctly.

### Detail B

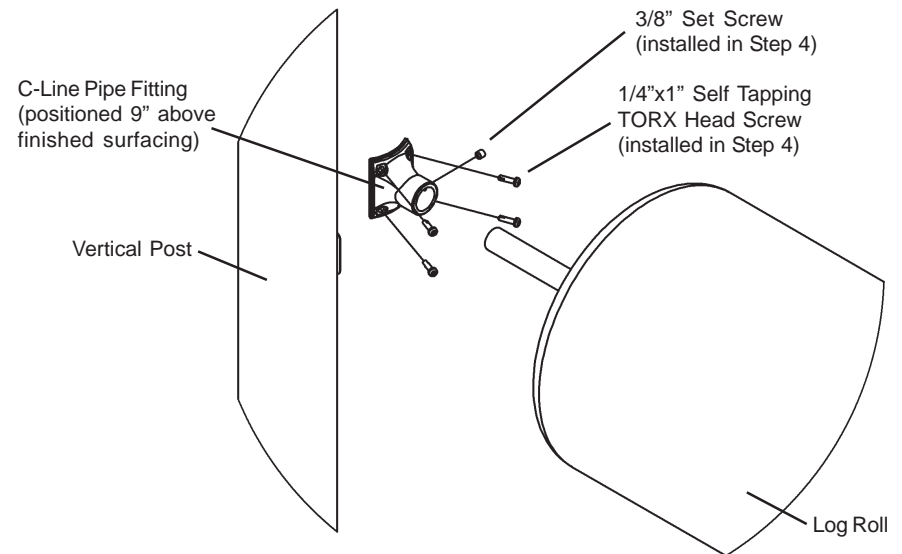

## STEP 4

Select eight 1/4"x1" self tapping TORX screws. Secure fittings to vertical post by installing four screws into each fitting. Lightly tighten until all four self tapping screws are installed. Then tighten all four self tapping screws (see Detail B). **NOTE:** Must use high speed 3/8" electric drill *w/clutch*. Use of any other driver may result in damage to tool and/or hardware! Repeat for other fitting. Verify that log roll is centered in grid (will be approximately 11-1/4" between log roll and vertical post -- see ELEVATION DETAIL on Page 3). Install and tighten one set screw per fitting.

## INSTALLATION GUIDELINES

### STEP 5

Select four C-Line pipe fittings with gaskets attached and two C-Grab handles. Place fittings over C-Grab handles as shown in Detail C. Remove backing from other side of gaskets. Hold C-Grab handles in position, making sure they are plumb and at correct height (see Detail C). **NOTE:** Bottom fitting of C-Grab handle should be 26" above fitting for log roll (see ELEVATION DETAIL).

### Detail C

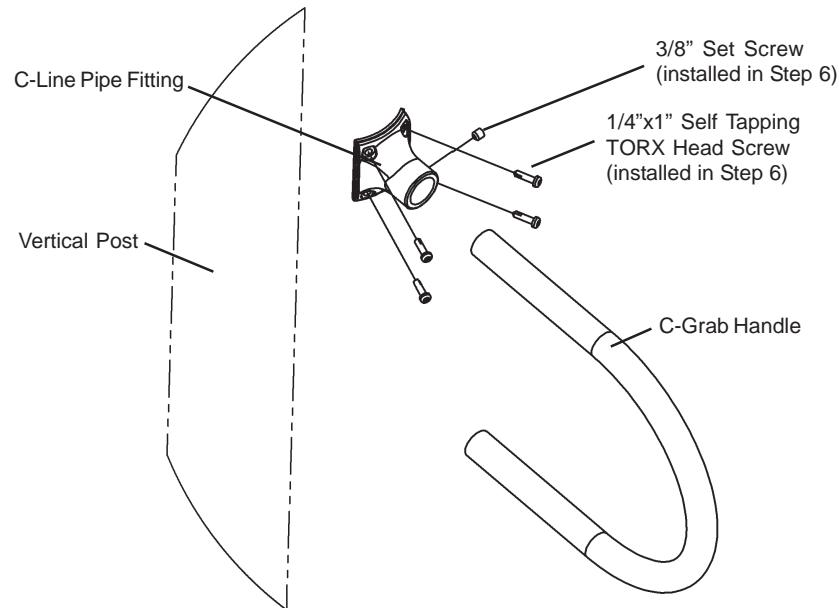

### STEP 6

Select eight 1/4"x1" self tapping TORX screws. Secure fittings to vertical post by installing four screws into each fitting. Lightly tighten until all four self tapping screws are installed. Then tighten all four self tapping screws (see Detail B). **NOTE:** Must use high speed 3/8" electric drill w/clutch. Use of any other driver may result in damage to tool and/or hardware! Repeat for other fitting. Install and tighten one set screw per fitting.

### STEP 7

Verify that log roll and C-grab handles are level and that all hardware is tightened. Make sure vertical posts are plumb. Pour concrete into footings to correct level. **NOTE:** Concrete must have a minimum rating of 2,500 psi and must be mixed per manufacturer's recommendations. **Allow concrete to harden for at least 48 hours before use.**

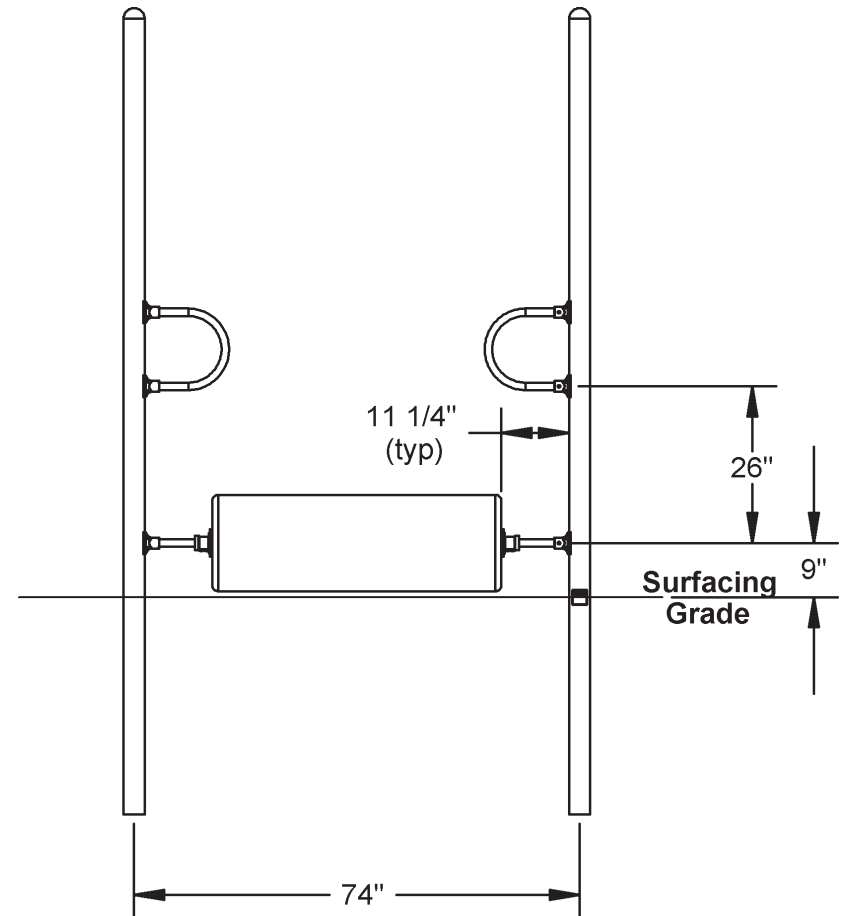

ELEVATION DETAIL

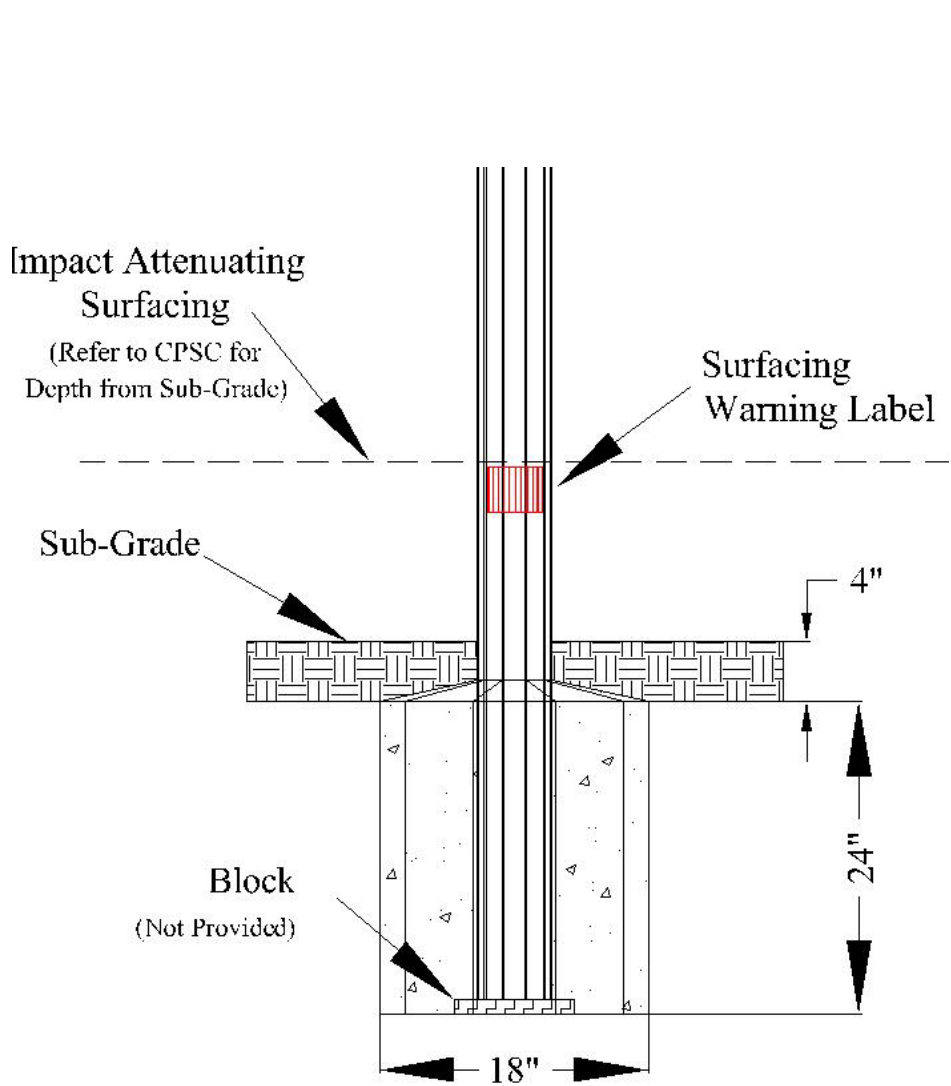

**FOOTING ELEVATION**

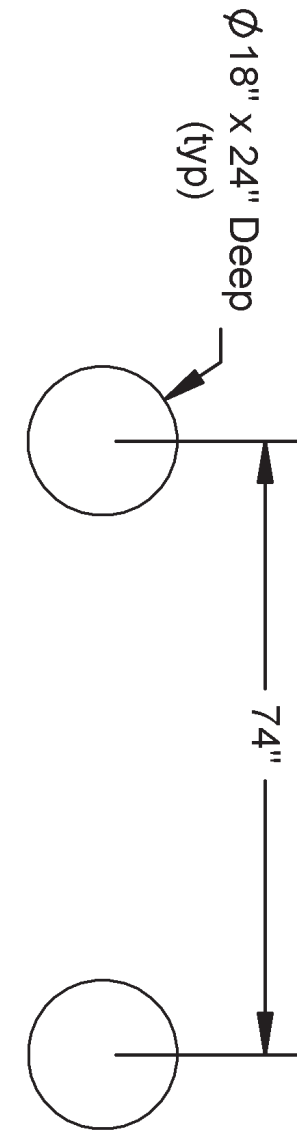

**FOOTING LAYOUT**

**PRODUCT SPECIFICATIONS****BILL OF MATERIALS  
PART/HARDWARE LIST**

| ITEM NO. | QTY. | PART NO.   | DESCRIPTION                                     |
|----------|------|------------|---|
| 1        | 1    | RPA02011XX | Pre-Assembly - Log Roll C-Line                  |
| 2        | 2    | FAB31002XX | Fab - 1 1/4" x 14" "C" Grab Handle              |
| 3        | 6    | CTG10004XX | Fitting - 3-1/2" C-Line Pipe Mount (Coated)     |
| 4        | 6    | HDW32550XX | 3 1/2" Sealing Gasket                           |
| 5        | 24   | 2080000192 | Screw - 1/4" x 1" Self Tapping TORX w/<br>Patch |
| 6        | 6    | 2080040192 | Set Screw - 3/8" x 3/8" Allen Head              |
| 7        | 2    | 30003011XX | Post - 3.5" x 132" w/Cap Adventure              |

**HARDWARE**

- Tamper resistant
- Special tool required for install

**LOG ROLL**

- 1st quality linear low density Polyethylene (ExxonMobil LL8450)
- Rotational molded
- 2,550 psi tensile strength (ASTM D638)
- Mold-in graphics
- UV stabilized
- Anti-static inhibitors

**C-GRAB HANDLE**

- 1-1/4" O.D. round galvanized steel
- 14 gauge steel
- 50,000 psi yield strength (ASTM E-8)
- 55,000 psi tensile strength (ASTM E-8)
- Triple zinc coated undercoat
- Powder coat finish

**PRODUCT SPECIFICATIONS****FITTING**

- Aluminum alloy (GM70B) manufactured and tested in accordance with the following ASTM Standards: B179-68, B108-68, E10-66, E8-66
- Powder coat finish
- Predrilled

**SEALING GASKET**

- Neoprene rubber
- 60 +/- 5 durometer hardness
- Double sided adhesive

**VERTICAL POST**

- 3.5" O.D. round steel tube
- 13 gauge steel
- 50,000 psi yield strength (ASTM E-8)
- 55,000 psi tensile strength (ASTM E-8)
- Triple zinc coated undercoat
- Powder coat finish

**PRETREATMENT WASH PRIMER**

- 4860-420 primer / 1000-44 activator
- Polyvinyl-butyril resin based primer
- Used on all mild steel and all weld joints
- Designed to give adhesion to a wide variety of metal substrates
- Provides added metal protection against rust
- Imparts extra durability to topcoat (powder coat)
- When reduced properly, it meets the definition of a "pretreatment" primer found in many air quality regulations

**POWDER COAT FINISH**

- TGIC Polyester
- Electrostatic application
- Baked-on @ 400 degrees
- 5-7 mills thick
- Lead free
- High gloss
- No peel / No flake finish
- Resistant to salt spray (ASTM B117)
- Resistant to humidity (ASTM D2247)
- Direct/Indirect impact 120 in. pounds (ASTM D2794)
- Good to excellent resistance to most solvents, oils, acids and alkalis